

GYMNASTICS

ATHLETICS

TRAINING/DRILLS

SPORTS HALL EQUIPMENT

MULTISPORTS

SPORTS EQUIPMENT  
PHYSICAL EDUCATION



# DIMASPORT

+33(0)1 64 40 05 70 +33(0)1 64 40 00 37 [www.dimasport.fr](http://www.dimasport.fr) [info@dimasport.fr](mailto:info@dimasport.fr)



**More quality**

Dima is an advocate of rigorous manufacturing processes which **reinforce the quality** of our products (handles stitched into the thickness, reinforcing straps on seams of folding mattresses, high-density foam, etc.).

**More ideas**

Dima, at the cutting edge of innovation, regularly brings out **new products**.

**More savings**

Dima helps you to **benefit from savings** in terms of packaging and handling with our different variety packs. In addition, the quality of our products means that you won't have to renew them as often.

**More guarantee**

If Dima is the only company to offer you a **5-year guarantee**, it's not just by chance!

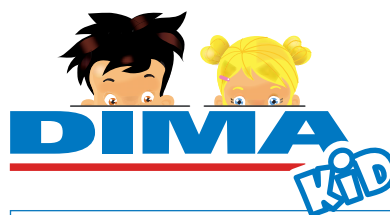

ATHLETICS CATALOGUE

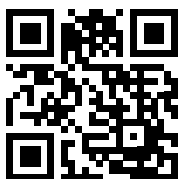

**DIMA EXPERTISE FOR 0-6 YEAR-OLDS**

- Kindergartens
- Playschools
- Schools
- Gym clubs

**DIMAKID** online store [www.dimakid.fr](http://www.dimakid.fr)

CATALOGUES DISPONIBLES SUR [www.dimasport.fr](http://www.dimasport.fr)

**DIMASPORT**  
SPORTS EQUIPMENT

1 bis, rue Louis Armand  
B.P 91 - 77834 OZOIR-LA-FERRIÈRE CEDEX  
FRANCE  
Tel.: +33 1 64 40 05 70 - Fax: +33 1 1 64 40 00 37  
[www.dimasport.fr](http://www.dimasport.fr) - [info@dimasport.fr](mailto:info@dimasport.fr)



# DIMASPORT

SPORTS EQUIPMENT

## DIMASPORT, DESIGNER & MANUFACTURER

Both designers and manufacturers of sports equipment, our metalwork and stitching facilities are located in the Paris region and produce all of our equipment. With our top-class manufacturing resources spread across a site comprising three factories together with our unparalleled know-how, you're sure to benefit from **quality and service at best prices.**



## DIMASPORT = SAFETY

To guarantee the safest conditions for users and to certify the quality of our manufacturing, **our gymnastic landing products are tested and approved by independent bodies and are compliant with the norm NF EN 12503.**



## GYMNASTICS

Pédagogym.....	12	Blocks.....	23
Mats.....	16	Trampettes.....	23
Tracks.....	18	Apparatus.....	24
Areas.....	19	Beam / Platforms.....	26
Mattresses.....	20	Prima Gym Apparatus.....	28
Dual density Mattresses.....	21	Gym kid.....	29
Folding Mattresses.....	22	DimaKid infant agility.....	30

## ATHLETICS

Stopwatches.....	34	Throwing targets.....	48
Measurements.....	35	Javelins.....	49
Small equipment.....	36	High jump.....	50
Starting blocks.....	38	Pole vault.....	54
Hurdles.....	39	Poles.....	56
Shot put.....	44	Pole Vault Packs.....	58
Hammers.....	45	Sheds.....	59
Discuses.....	46	Athletics packs.....	60
Measurement.....	46	School and teaching equipment.....	61

## TRAINING / DRILLS

Jumping.....	64	Marking equipment.....	72
Strengthening.....	66	Training kits.....	78
Hurdles.....	68	Storage.....	80
Pedagogym.....	71		

## SPORTS HALL EQUIPMENTS

Crash mattresses for climbing walls.....	84	Cotton tatamis.....	87
DIMA climbing crash pads.....	84	Vinyl tatamis.....	87
Landing mats for artificial climbing structures.....	85	Afnor tatamis.....	87
Beginners wrestling mat.....	86	Cotton judo covers.....	87
Reversible multi-sport surfaces.....	86	Rice straw type judo covers.....	87
Club wrestling mat.....	86	Made-to-measure post protectors for outdoor use.....	88
Reversible covers - 1 circle/4 circles.....	87	Rugby post protectors.....	88
School wrestling and combat mats.....	87	Wall pads for indoor and outdoor use.....	89

## MULTISPORTS

Badminton.....	92	Orienteering.....	97
Rackets and accessories.....	92	Juggling and circus.....	98
Badminton posts.....	94	Circus school packs.....	100
Table tennis.....	96		



**DIMA**  
Official's Clipboard  
essential for teaching and training

EXCLUSIVE TO  
**DIMA**

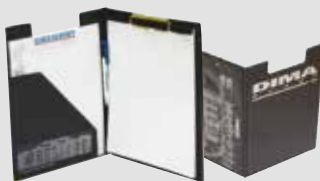

FOR ANY INFORMATION OR SPECIFIC REQUESTS, DO NOT HESITATE TO CONTACT OUR SALES TEAM AT YOUR DISPOSAL.

+33 1 64 40 05 70

# DIMASPORT

SPORTS EQUIPMENT



## INVENTOR OF SPORTS EQUIPMENT

Dimasport has more than 50 years of experience in the design, manufacture and distribution of sports equipment, putting its expertise to use for the benefit of local authorities, sports clubs and organisers of sporting events.

An experienced team offers you top-quality equipment to do sport in the safest conditions, from beginners to competition level.

## MANUFACTURING TOP QUALITY PRODUCTS

All of our manufacturing takes place in our own factories and our goods are subjected to the most stringent controls right up until they are dispatched. We take the greatest care in selecting our raw materials so as to produce equipment of the highest possible quality. Our products benefit from a 5-year guarantee.



**DELIVERING AN EXTREMELY  
EXTENSIVE PRODUCT RANGE**  
From mainstream sports activities to recreation and play.

A small business serving its clients, which manufactures in its own factories in France.

## INNOVATION SERVING SPORT

Every product enhancement we make aims to constantly improve the safety of playing a sport. Our quality and innovation standards are set and monitored by groups of athletes, physical education teachers and sports club leaders.

## OFFICIAL SUPPLIER TO MAJOR INTERNATIONAL COMPETITIONS

Dimasport equips the largest sporting events and meetings with its IAAF-compliant equipment and its certified top-level competition products



# A SUPPLIER THAT LISTENS AND ADVISES YOU

AT DIMASPORT YOU WILL ALWAYS BE ABLE TO FIND A SPECIALIST:

## A TEAM AT YOUR SERVICE

To offer you advice and support in choosing your equipment.

Specialists in sports equipment, we help you choose what best suits your requirements, from beginners to competition level.

### CONTACT OUR TEAM OF ADVISORS

Tel. +33(0)1 64 40 05 70

E-mail: [info@dimasport.fr](mailto:info@dimasport.fr)

Fax: +33(0)1 64 40 00 37

## ORDERING WITH DIMASPORT COULDN'T BE EASIER:

### 1 Prepare your order on [www.dimasport.fr](http://www.dimasport.fr)

All of our catalogues are available online.

### 2 Place your order.

Send your order request:

BY FAX : +33(1) 64 40 00 37

BY E-MAIL :

BY TÉL : +33(1) 64 40 05 70

[info@dimasport.fr](mailto:info@dimasport.fr)

BY POST :

1 bis rue Louis Armand  
BP 91

77834 Ozoir-la-Ferrière cedex  
France

Dimasport guarantees you top-quality service:

- Step-by-step order tracking
- Worldwide deliveries
- Specialist aftersales service.

## DIMASPORT

### AND SUSTAINABLE DEVELOPMENT



▄ Sustainable Development is development which meets the needs of the present without compromising the ability of future generations to meet their own needs. ▄▄

*(United Nations World Commission on Environment and Development).*

At Dimasport, we have pledged to change our work methods and organisation as necessary to enable better management of the planet's natural resources. We work with responsible suppliers (Certipur certification, ISO 14001).

We choose products which have the least impact on the environment and working conditions: raw materials controlled by REACH, solvent-free inks and varnishes, phthalate-free and hazardous product-free mats and mattresses for small children, etc.

### DIMASPORT, A RESPONSIBLE MANUFACTURER

- An eco-responsible approach
- Waste management (recycling of foam waste)
- Optimisation of raw materials with low-waste processes (since we are manufacturers)
- Optimisation of transport (since we manage our own deliveries)
- Optimisation of packaging.

# DIMASPORT

SPORTS EQUIPMENT

## DIMA TIPS What to do with...

As a company which is always close to the needs of its customers, Dimasport has decided to provide answers to a question asked by a great many users, leaders, teachers and trainers:

### HOW TO GET THE MOST OUT OF THE EQUIPMENT AND WHAT TO DO WITH IT

We therefore called on the expertise of a leading specialist in sports agility and skills to help us in this task.

#### JACQUES PIASENTA

The French athletics trainer with the most titles, and a teacher above all.

His objective is to **facilitate the development of motor capabilities and skills** whatever the discipline, age or proficiency level of the athlete or child.

We considered it fitting and natural for the leading manufacturer and creator of sports equipment team up with **an enthusiast of technique and an unbridled inventor of "exercises"** in order to **optimise, offer up new ideas and enable the easy and versatile use of some of our products.**

We have therefore developed

## DIMA'S "What to do with..." Factsheets

These factsheets, presented like cookery recipes, will help to make equipment use easier by recommending suitable exercises.

In the perspective of helping you in your educational approach, we have inserted a selection of these factsheets in this catalogue.

You can find more on our web site [www.dimasport.fr](http://www.dimasport.fr) (in French).

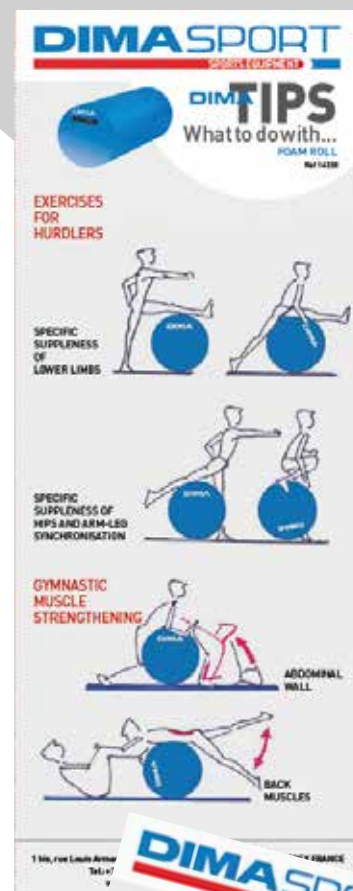

# A DEDICATED CUSTOMER SERVICE DEPARTMENT

The DIMA team is made up of genuine specialists here to help you with experience spanning more than ten years in a firm which has been active on the market for almost 50 years.

At DIMA, you are in direct contact with the manufacturer: your account manager will deal with your requirements personally and help you with all of your tasks, whether a simple query, a request for an estimate, order tracking, delivery, etc.

**Aftersales service also happens here**, because our products are manufactured in our factories on the same site as our sales offices, and this guarantees a highly reactive service and unparalleled availability.

**Whether a local authority, an educational establishment, a sports club or a personal customer, and whatever your country, the Dima sales team will provide you with reactive and appropriate assistance for your needs.**

## **Made to Design:**

If you wish to equip a stadium, a sports hall or facility or a gymnasium, we can help you with your design and establish your equipment requirements. With our long standing experience, we can tell you what is necessary and what's not, providing you with the most cost-efficient estimate for your needs.

## **Public Procurement:**

We can assist you with the authoring of all of your specifications aimed at your contractors, such as layout plans, compliance certificates and installation instructions. You can rest assured that your requirements are fulfilled along the entire length of the supply chain, from equipment definition to its installation.

## **Made to Measure:**

As not all facilities, particularly in club and school environments, are standard in shape and size, we can design and manufacture sports equipment to accurately fit into the space you have available. We can closely monitor our special manufacturing requests, as our factory is located next door to our offices. Your dreams of a versatile and well-equipped hall can come true thanks to our made-to-measure service.

## **Experts in Logistics:**

We ship our products to all countries and study the best options for you in terms of packaging and speed so that you receive your products when you need them and cost-effectively. Ask for an estimate today!

**CONTACTING US IS EASY...**

+33(0)1 64 40 05 70

+33(0)1 64 40 00 37

info@dimasport.fr



**OUR ADDRESS: 1 bis rue Louis Armand  
BP 91 - 77834 Ozoir-la-Ferrière cedex - France**

## **LOCAL AUTHORITIES**



Christophe DESBOUIS

## **SCHOOLS AND SPORTS CLUBS**



Valérie BIRAUD

## **EXPORT**



Marie-Laure HAMM

# PRODUCT INDEX

## GYMNASICS



## ATHLETICS

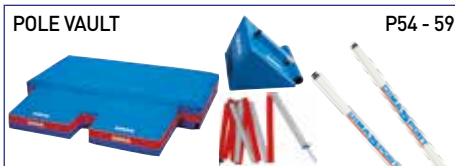
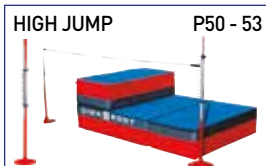
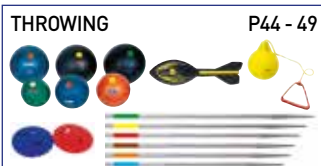

## TRAINING

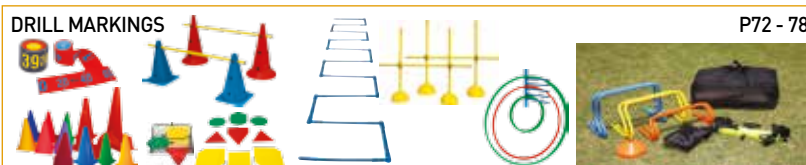

## SPORTS HALL EQUIPMENT



## MULTISPORTS





## A

Apparatus	24, 25, 26, 27
Athletics pack	58, 60
Athletics	33-61

## B

Babygym	28-31
Badminton kit	92-93
Badminton	91-95
Bags, Dima	58, 81
Balance ball	98
Ballast, badminton	95
Balls, juggling	99-101
Balls, table tennis	96
Balls, throwing	44, 49
Banners, section	35
Bars, high	26, 28
Bars, mixed	24, 25
Bars, parallel	24, 25, 28
Bars, traction	65
Bars, uneven	24, 25, 28
Base (drill markings)	77
Basket (storage)	80
Bats, table tennis	96
Beam	15, 26, 27
Belt	66, 67
Bench	64 - 65
Bricks	74

## C

Circus	98-101
Clapper	36
Climbing	83, 84, 85
Clip, rotating	77
Clubs, juggling	99
Compass	97
Cones	72, 78
Cones, flat	72
Covers, Dimagym	20-21
Cover, high jump landing system	51-52
Covers, judo/wrestling mats	86, 87
Covers, weather	51, 53, 54
Crash pads	84
Crossbars	50, 55
Cupboard	80

## D

Diabolo	98, 100, 101
Discus	46, 47
Drill markers	74, 75

## E

Elastiband	67
Elastic cord	67

## F

Floors, exercise	19
Floors, gym	18, 19

## G

Go go	98
Gymnastics	11-31

## H

Hammer	45
Height gauge	50, 55

High jump	50-54
Hoops	37, 48, 61, 74, 76, 77, 78
Hurdle	39-43, 68-70, 72, 73, 77, 78
Hurdle, foam	41, 42

## I

Incline	13
Infant agility	28-31

## J

Javelin	49
Judo	86-87
Juggling	98-101
Juggling pack	100, 101

## K

Kid courses	29, 30, 31
-------------	------------

## L

Ladder, agility 37, 75, 76	37, 75
Ladder, foot speed	37, 75
Ladder, hoop	76
Landing system	51-55
Landing system, folding	51

## M

Markers	73, 74, 77, 97
Markings, drill	72-78
Mats, climbing	84, 85
Mats, gym	16-19
Mats, jumping	61
Mats, wrestling	86, 87
Matting, judo, wrestling	86, 87
Matting, multisports	86
Mattress, 1-piece	23, 51, 52
Mattress, folding	22, 25, 26
Mattress, gym	20-25
Mattress, pole vault	54
Measurement	35
Medicine ball	45, 66
Megaphone	35
Mobility courses	74
Monocycle	98
Motor skills	38-31
Multisports	92-101

## N

Net, badminton	94, 95
----------------	--------

## O

Official's Clipboard, Dima	36
Orienteering	97
Orienteering card	97

## P

Pads, wall	89
Pedagogym	13, 71
Platform (gymnastics)	15, 27
Platform (landing system)	51, 53
Plyometric foam blocks	64
Podium	36
Podometer	35
Pole vault	54-58
Posts, badminton	94, 95
Power sled	38, 67
Prima gym	28

Protectors, pillar	88
Protectors, shed	59
Push-up bars	65

## R

Rack, storage	66, 80
Rackets, badminton	92, 93
Relay batons	36
Resistance belts	67
Rings, juggling	99, 100, 101
Rings, throwing	47
Rolla bolla	98
Rugby	88

## S

Sheds	53-59
Shot	44
Sports hall equipment	83-89
Springboard	14, 27
Staircase, foam	61
Starting blocks	38
Stilts	98
Stopwatch	34-35
Storage	81-81
Straps	84
Stride indicators	37, 75
Synthetic roll	38, 70

## T

Take-off mat	61
Tape, metric	37, 46, 72
Tape, Velcro	72
Tape, vinyl	34, 46, 74
Target	48
Tatamis	87
Throwing areas	44, 61
Throwing factsheet	46
Throwing implements	44-49
Tip, pole vault	57
Track, gymnastics	18, 19, 64
Training	63-81
Training dummies	78
Training kit	79
Trampoline	23
Trampette	28
Transportation cart	17, 23, 39, 44-46, 49, 76, 80, 93
Turbojav	49

## U

Uprights, high jump	50
---------------------	----

## V

Vault box	55, 61
Vest, weighted	66
Vortex	49

## W

Wall bars	65
Wheel, measuring	35, 46
Whistles	36
Wrestling	86, 87

# DIMASPORT

SPORTS EQUIPMENT

## MANUFACTURER

WE MANUFACTURE OUR PRODUCTS IN OUR FACTORIES NEAR PARIS.

### METALWORK

We cut, drill and weld the steel ourselves.  
Every production stage is rigorously controlled.



**MADE IN**  
OUR FACTORY  
IN PARIS REGION

### TARPAULINS

For over 50 years, we have been constantly improving our processing methods to offer top-quality products.



### RAW MATERIALS



Our foams are of the highest quality and we know their composition.



Our canvases are inspected and certified.



We select our steels carefully and we know where they come from.

We require unremittingly high standards from our suppliers, because the quality of our raw materials largely guarantees the quality of our products.

Foam is a costly but fundamental component in our products; we are constantly attentive to its quality and make no compromises.

RESPONSIBLE FOR PRODUCTION  
TO FULFIL **YOUR SATISFACTION**  
**TOTAL COMMITMENT FROM DIMA**

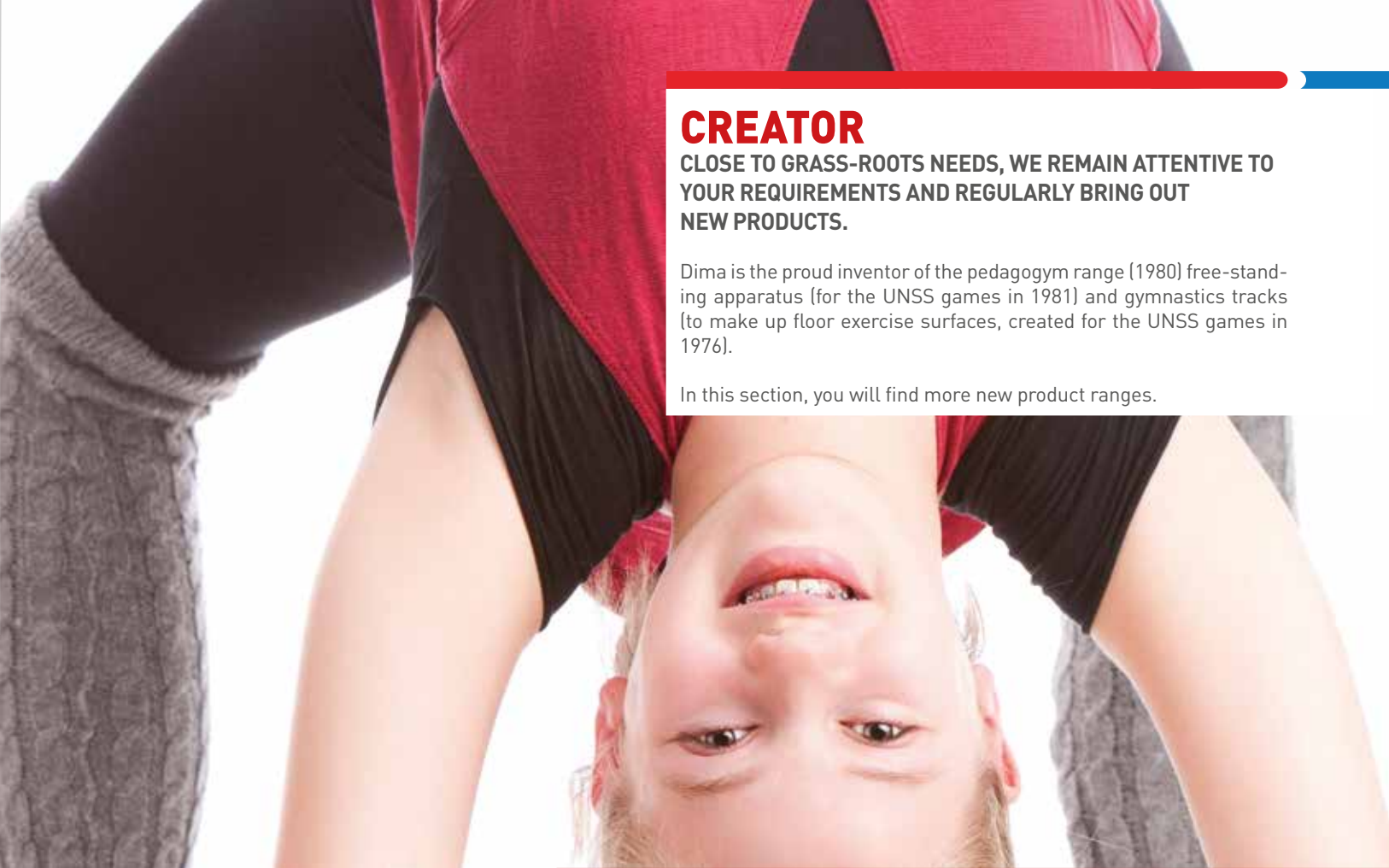

## CREATOR

CLOSE TO GRASS-ROOTS NEEDS, WE REMAIN ATTENTIVE TO YOUR REQUIREMENTS AND REGULARLY BRING OUT NEW PRODUCTS.

Dima is the proud inventor of the pedagogym range (1980) free-standing apparatus (for the UNSS games in 1981) and gymnastics tracks (to make up floor exercise surfaces, created for the UNSS games in 1976).

In this section, you will find more new product ranges.

## CONTENT GYMNASTICS

Pedagogym .....	12
Mats .....	16
Tracks .....	18
Areas .....	19
Mattresses .....	20
Dual density Mattresses .....	21
Folding Mattresses .....	22
Blocks .....	23
Trampettes .....	23
Apparatus .....	24
Beams / Platforms .....	26
Prima Gym Apparatus .....	28
Gym kid .....	29
Dimakid infant agility .....	30

# GYMNASTICS

**PERFECTLY SUITED TO AGILITY AND GYMNASTIC WORK**

From **beginners** to **top-level** our high-density foam modules will allow you to create an infinite range of well-adapted and safe combinations.

- Tear-proof handles
- Supplied with exercise decals printed on each module
- Made from high density polyurethane foam, 24kg/m<sup>3</sup>, 30m<sup>3</sup>, 75kg/m<sup>3</sup>, with a 1000 denier Tergal cover.
- Compliant with flame retardancy standard M2 - Phtalate-free
- Leather grain topside, non-slip underside.

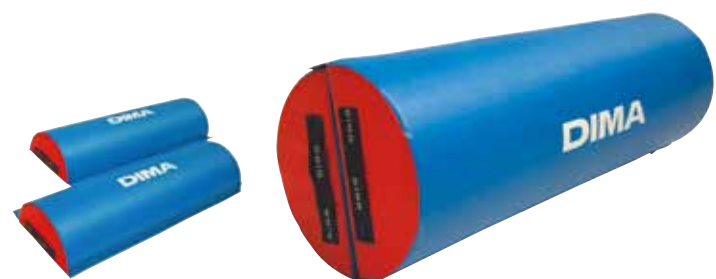
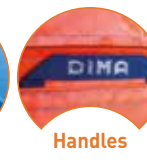
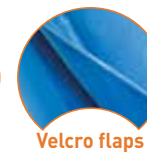
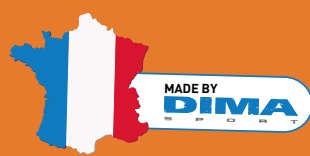

## 2-SECTION CYLINDER

Made up of 2 half cylinders which fix together using wide Velcro flaps

Ref	Product description
22041	2-section cylinder 120 x Ø 40cm



## BLOCK

Ref	Product description
22010	Maxi block 150 x 60 x 60cm
24200	Block 105 x 45 x 45cm



## INCLINE

Ref	Product description
22035	Maxi incline 140 x 60 x 60cm
24220	Incline 105 x 45 x 45cm



## BROKEN WEDGE

Ref	Product description
22020	Maxi broken wedge 150 x 60 x 60cm
24210	Broken wedge 105 x 45 x 45cm



## CYLINDER

Ref	Product description
22040	Maxi cylinder 150 x Ø 60cm
24230	Cylinder 105 x Ø 45cm

5 year guarantee



**HEXAGON**

Ref	Product description
22050	Maxi hexagon 150 x 60 x 60cm
24240	Hexagon 105 x 45 x 45cm



**2-PART RECTANGLE**

Made up of 2 inclines which fix together with wide Velcro bands.

Ref	Product description
22036	140 x 60 x 60cm (2 incline modules: 140 x 60 x 50 /10cm)
22037	105 x 45 x 40cm (2 incline modules: 105 x 45 x 30 /10cm)

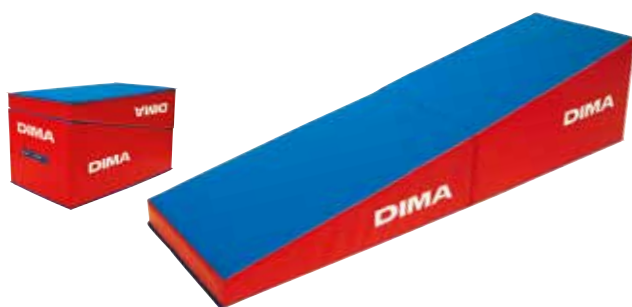

**FOLDING INCLINE**

Ref	Product description
22034	Maxi folding incline 200 x 60 x 50/10cm (Dim. folded: 100 x 60 x 60cm)



**STABILISED CYLINDER**

Ref	Product description
24300	Green / yellow 50 x 35 - Ø 40cm
24301	Blue / red 60 x 50 - Ø 60cm



**SOMERSAULT MAT**

Ref	Product description
KB013207	200 x 60 x 25 / 5cm (folded 100 x 60 x 30cm)



**INCLINE WITH PLATFORM**

Ref	Product description
24310	200 x 100 x 40 / 5cm
24311	220 x 150 x 40 / 5cm

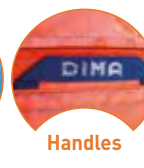

### 30-COLOUR MAXI VAULTING HORSE

Made up of a 30cm rounded module, 1 x 10cm high module, 1 x 20cm high module and 1 x 80cm base module.

30KG  
FOAM DENSITY

Ref	Product description
22260	150 x 80 x 140cm

Our modules are:

- Made up of various **modular** sections which **attach using wide Velcro flaps**
- fitted with **wide handles**
- Exercise decals printed on Pedagogym equipment



75KG  
FOAM DENSITY

### MAXI LEATHER VAULTING HORSE

Made up of a 30cm rounded module, 1 x 10cm high module, 1 x 20cm high module and 1 x 80cm base module.

30KG  
FOAM DENSITY

Ref	Product description
22270	150 x 80 x 140cm

Ref 24260



Ref 22250

### VAULT HORSE

Made up of a 19cm rounded module, 1 x 7cm high module, 1 x 14cm high module and 1 x 60cm base module.

30KG  
FOAM DENSITY

Ref	Product description
24260	Vaulting horse 105 x 55 x 100cm

### MAXI VAULTING HORSE

Made up of a 30cm rounded module, 1 x 10cm high module, 1 x 20cm high module and 1 x 80cm base module.

Ref	Product description
22250	Maxi vaulting horse 150 x 80 x 140cm

### DYNAMIC FOAM SPRINGBOARD

Made of several layers of neoplene foam for enhanced energy return and resistance, covering a wooden board for better rigidity. Velcro end for attachment to other modules.

Ref	Product description
22100	Dynamic foam springboard 100 x 65 x 25cm

### FOAM SPRINGBOARD

Ref	Product description
22105	Foam springboard 120 x 60 x 25cm



Ref 22100

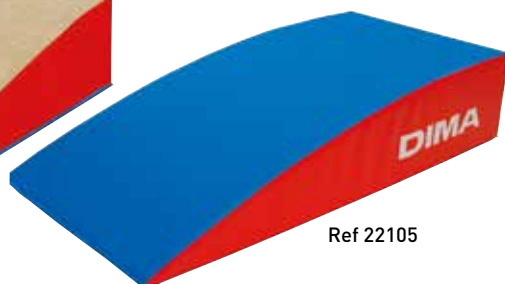

Ref 22105

**FOAM BEAM**

Ideal for beginners and training.  
Height 15cm. Dense foam.

Ref	Product description
24030	Beam: length 3 m
24035	Beam: length 2 m



- Non-slip synthetic leather top layer,
- Leather grain cover,
- Non-slip underside.

**5** year guarantee

Ref 22200



Ref 24250



**PLATFORM**

Ref	Product description
24250	Platform 120 x 50 x 70cm
22200	Maxi Platform n°6 170 x 70 x 100cm

**24KG**  
FOAM DENSITY

Ref 22320



Ref 22321



**3 & 4 LEVEL PLATFORM**

3-level platform: Made up of 2 x 40cm modules and 1 x 20cm module.  
4-level platform: Made up of 2 x 40cm modules and 2 x 20cm module.

Ref	Product description
22321	3 level platform 160 x 60 x 100cm
22320	4 level platform 160 x 60 x 120cm

**ÅO-COLOUR MAXI PLATFORM N°7**

Made up of two modules of 80 and 20cm.

Ref	Product description
22210	170 x 70 x 100cm



**75KG**  
FOAM DENSITY

**24KG**  
FOAM DENSITY

**LEATHER MAXI PLATFORM N°8**

Made up of two modules of 80 and 20cm.

Ref	Product description
22215	170 x 70 x 100cm



# GYMNASTICS

CERTIFIED COMPLIANT WITH SAFETY STANDARD NF EN 12503 AND INFANT AGILITY STANDARD NF S54-300

5 year guarantee

Made from dense polyethylene foam (35kg/m<sup>3</sup>)

- Covered with a 1000 denier Tergal canvas coated with 650g PVC, **leather grain topside and non-slip underside.**
- **Certified Flame-retardant to M2 standard**, certified to French norms and **phthalate-free.**
- This range of mats is very versatile and particularly well-suited to use in schools for **intensive collective use.**



## SCHOOL MATS

The definitive basic mat, plain colour, available in several sizes and thicknesses.

23500	200 x 100 x 3cm	23810	200 x 125 x 4cm
23510	200 x 100 x 4cm	23815	200 x 125 x 5cm
23800	200 x 100 x 5cm	23820	200 x 150 x 5cm



## FULLY ASSEMBLING MATS

The mats attach together with wide 5cm Velcro bands stitched into the seams, on all edges, allowing for solid assembly to create play areas, combat mats or gymnastic trails.

23580	200 x 100 x 3cm	23610	200 x 125 x 5cm
23590	200 x 100 x 4cm	23620	200 x 150 x 5cm
23600	200 x 100 x 5cm	23630	300 x 100 x 5cm

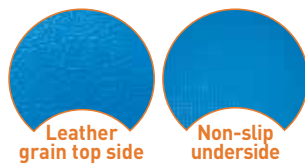

Leather grain top side

Non-slip underside



**2-COLOUR END ASSEMBLING MATS WITH RED EDGING**

Mats with red bands on outer edges, providing visual guidance during exercises.

23120	<b>200 x 100 x 4cm</b>	23160	<b>200 x 150 x 4cm</b>
23150	<b>200 x 100 x 5cm</b>	23170	<b>200 x 150 x 5cm</b>



**SCHOOL MATS WITH REINFORCED CORNERS**

Same manufacturing method as standard mats but with reinforced saddle stitch corners for intensive use and frequent moving.

23700	<b>200 x 100 x 4cm</b>	23710	<b>200 x 100 x 5cm</b>
-------	------------------------	-------	------------------------



**FULLY ASSEMBLING MATS WITH REINFORCED CORNERS**

Same manufacturing method, with wide Velcro strips on all edges to make up larger areas.

23730	<b>200 x 100 x 4cm</b>	23740	<b>200 x 100 x 5cm</b>
-------	------------------------	-------	------------------------



**HORIZONTAL TRANSPORTATION CART**

Wooden deck mounted on a metal framework with 4 wide non-marking castors including 2 swivelling and two rubber wheels for corner protection.

Ref	Product description
22350	Horizontal transportation cart 200 X 100cm

**VERTICAL TRANSPORTATION CART**

Very manoeuvrable cart: one axis and two wheels.  
Space required when empty: 100 x 50cm.

Ref	Product description
22352	Vertical transportation cart

**VERTICAL TRANSPORTATION CART WITH RAILS**

Very manoeuvrable cart designed for mattresses and landing systems, fitted with 4 swivelling castors including 2 with brakes to facilitate loading and unloading. Support rails on either side (80cm and 120cm). Base measures 200 x 70cm. Space required 200 x 75 x 136cm. Maximum load 400kg.

Ref	Product description
22353	Vertical transportation cart with support rails

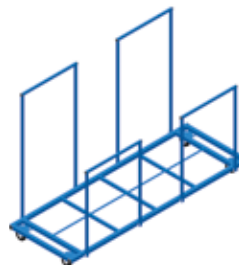

Ref 22353



Ref 22352



Ref 22350

# GYMNASTICS



- Covered with a 1000 denier Tergal canvas coated with 650g PVC, **leather grain topside and non-slip underside.**
- Certified **Flame retardant to M2 standard**, certified to French norms and **phthalate-free.**
- Designed for **easy and fast storage** in the least possible space, the tracks and areas fold up easily for a **minimum footprint.**
- This range of mats is very versatile and particularly well-suited to use in schools for **intensive collective use.**
- **The quality of our seams and our expertise** in terms of manufacturing help to deliver a flat and consistent surface.

**CERTIFIED COMPLIANT WITH SAFETY STANDARD NF EN 12503 AND INFANT AGILITY STANDARD NF S54-300**

Made from springy dense polyethylene foam.

**+ DIMA EXTRAS**

Fitted with handles stitched into the full width of the track (making them easier to carry and avoiding handle tear)

**5 year guarantee**

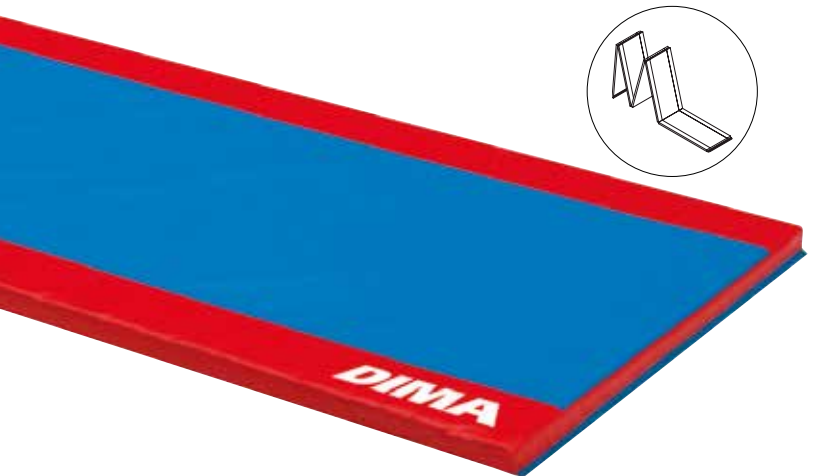
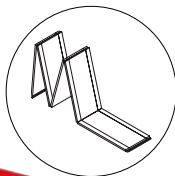
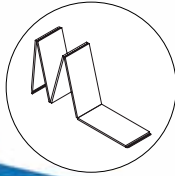
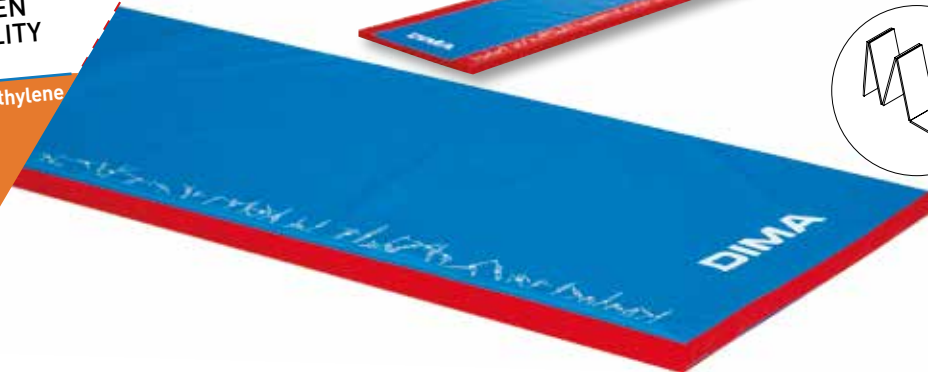

## STANDARD TRACKS

Ref	Product description
22400	600 x 100 x 5.5cm (Foldable into 2; folded size: 200 x 100 x 16.5cm)
22410	600 x 200 x 5.5cm (Foldable into 4; folded size: 200 x 150 x 22cm)
22415	1000 x 100 x 5.5cm (Foldable into 5; folded size: 200 x 100 x 27.5cm)
22420	1200 x 200 x 5.5cm (Foldable into 6; folded size: 200 x 150 x 44cm)

## END ASSEMBLING STANDARD TRACKS

Fitted with wide Velcro flaps to make up exercise tracks.

Ref	Product description
22360	600 x 100 x 5.5cm (Foldable into 2; folded size: 200 x 100 x 16.5cm)
22330	600 x 200 x 5.5cm (Foldable into 4; folded size: 200 x 150 x 22cm)
22310	1000 x 100 x 5.5cm (Foldable into 5; folded size: 200 x 100 x 27.5cm)
22340	1200 x 200 x 5.5cm (Foldable into 8; folded size: 200 x 150 x 44cm)

## END ASSEMBLING ÆO-COLOUR TRACKS WITH RED EDGING

Tracks with red band on outer edges, providing visual guidance during exercises.

Ref	Product description
23875	600 x 100 x 5.5cm (Foldable into 3; folded size: 200 x 100 x 16.5cm)
23870	600 x 200 x 5.5cm (Foldable into 4; folded size: 200 x 150 x 22cm)
23110	1000 x 100 x 5.5cm (Foldable into 5; folded size: 200 x 100 x 27.5cm)
23880	1200 x 200 x 5.5cm (Foldable into 8; folded size: 200 x 150 x 44cm)

FULLY ASSEMBLING STANDARD TRACKS

Ref	Product description
22285	600 x 100 x 5.5cm (Foldable into 3; folded size: 200 x 100 x 16.5cm)
22290	600 x 200 x 5.5cm (Foldable into 4; folded size: 200 x 150 x 22cm)
22295	1000 x 100 x 5.5cm (Foldable into 5; folded size: 200 x 100 x 27.5cm)
22300	1200 x 200 x 5.5cm (Foldable into 8; folded size: 200 x 150 x 44cm)

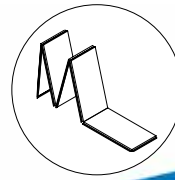

EXERCISE AREAS

Foldable into 50cm modules

Ref	Product description
23903	150 x 200 x 4cm (folded size: 1 piece 150 x 50 x 16cm)
23913	200 x 200 x 4cm (folded size: 1 piece 200 x 50 x 16cm)
23750	300 x 300 x 4cm (folded size: 1 piece 300 x 50 x 24cm)
23751	400 x 400 x 4cm (folded size: 2 pieces 200 x 50 x 32cm)
23752	500 x 500 x 4cm (folded size: 2 pieces 250 x 50 x 40cm)
23753	600 x 600 x 4cm (folded size: 2 pieces 300 x 50 x 48cm)
23916	300 x 250 x 4cm (folded size: 1 piece 250 x 50 x 24cm)
23917	400 x 250 x 4cm (folded size: 1 piece 250 x 50 x 32cm)
23918	500 x 250 x 4cm (folded size: 1 piece 250 x 50 x 40cm)
23919	600 x 250 x 4cm (folded size: 1 piece 250 x 50 x 48cm)

COLOURED EXERCISE AREAS IN OUR DIMAKID CATALOGUE PAGES 22-23

AND ON OUR DIMAKID WEB SITE [www.dimakid.fr](http://www.dimakid.fr)



ROLL-UP TRACKS

Perfect for making up multi-purpose exercise areas or training surfaces.

Made of springy and lightweight polyethylene foam, covered with carpet. Non-slip underside. Can be attached to each other using Velcro strips 10cm wide, 35mm thick.

Ref	Product description
23850	600 x 200cm
23851	1200 x 200cm
23852	1400 x 200cm
23853	Velcro strip 25 m

COMPACT STORAGE TRACK

Specifically designed to reduce storage requirements, this scalable and foldable track offers you excellent flexibility. Entirely foldaway into 50cm-wide strips, it takes up very little storage space. Its width and non-slip underside can help to create extensive exercise areas, bringing you greater safety. For even safer use, the ends have red edging.

Ref	Product description
23760	1000 x 100 x 5cm (folded size: 100 x 50 x 100cm)
23761	1200 x 200 x 5cm (folded size: 200 x 50 x 60cm)

# GYMNASTICS

## Compliant with safety standard NF EN 12503

- High quality polyurethane foam covered with 1000 denier flame-retardant M2 certified Tergal fabric.
- Leather grain finish and non-slip underside and an **air-escape grid all around the mattress** for a softer landing and recovery; made from 650g PVC.
- Removable cover with zip fastening on 3 sides.

**Non-tear handles with 8 stitch points into the thickness of the mattress allowing for easier transportation.**



MADE BY  
**DIMA**

**The definitive safety mattress. Specifically designed for intensive use.**

**5 year guarantee**

Replacement foam for gym mattresses on request  
Tel. +33 1 64 40 05 70 or info@dimasport.fr

## DIMAGYM SAFETY MATTRESS

### Thickness 10cm

Ref	Product description
23000	200 x 120 x 10cm
25190	200 x 140 x 10cm
25200	200 x 150 x 10cm
25220	240 x 200 x 10cm

### Thickness 20cm

Ref	Product description
23020	200 x 120 x 20cm
23025	200 x 150 x 20cm
23030	240 x 200 x 20cm
23040	250 x 200 x 20cm
23050	300 x 200 x 20cm
23060	360 x 200 x 20cm
23070	400 x 200 x 20cm

### Thickness 30cm

Ref	Product description
15955	300 x 200 x 30cm



## DIMAGYM REPLACEMENT COVERS

Ref	Product description
23280	200 x 120 x 10cm
23275	200 x 140 x 10cm
23260	200 x 150 x 10cm
23270	240 x 200 x 10cm
23285	200 x 120 x 20cm
23265	200 x 150 x 20cm
23300	240 x 200 x 20cm
23310	250 x 200 x 20cm
23320	300 x 200 x 20cm
23325	360 x 200 x 20cm
23330	400 x 200 x 20cm
23323	300 x 200 x 30cm



DIMA MANUFACTURES TO YOUR MEASUREMENTS  
PLEASE FEEL FREE TO ENQUIRE  
TEL +33 1 64 40 05 70  
OR info@dimasport.fr

## ÃO-COLOUR END ASSEMBLING DIMAVISUEL

This landing mattress is elaborately-made with its visual guides in red for safe exercises.

Fitted with 10cm wide Velcro bands on the top and underside to join together several mattresses solidly and safely.

Ref	Product description
23100	240 x 200 x 20cm
25110	300 x 200 x 20cm
25120	400 x 200 x 20cm

## REPLACEMENT COVERS FOR ÃO-COLOUR END ASSEMBLING DIMAVISUEL

Ref	Product description
23101	Cover 240 x 200 x 20cm
25111	Cover 300 x 200 x 20cm
25121	Cover 400 x 200 x 20cm



Dual-use mattress: a soft side for training and a hard side for competition and stable landings.

## DUAL DENSITY MATTRESS, FOR APPARATUS LANDINGS, REVERSIBLE WITH HANDLE

Made from 17cm of high quality polyurethane foam (24kg/m<sup>3</sup>) topped with a 3cm layer of firm polyethylene foam (30kg/m<sup>3</sup>), covered on both sides with 1000 denier FLAME-RETARDANT M2 certified leather grain Tergal surface and an **air-escape grid all around the mattress** for a softer landing. Removable cover with zip fastening on 3 sides. **Non-tear handles with 8 stitch points into the thickness of the mattress** allowing for easier transportation.

**THESE MODELS HAVE BEEN SPECIFICALLY DESIGNED FOR INTENSIVE USE IN CLUBS AND COLLECTIVE ENVIRONMENTS.**

## DUAL DENSITY REVERSIBLE MATTRESS

Ref	Product description
26214	240 x 200 x 20cm
26215	300 x 200 x 20cm
26203	400 x 200 x 20cm

## END ASSEMBLING DUAL DENSITY REVERSIBLE MATTRESS

Fitted with wide Velcro flaps (stitched across the width) to make the appropriate safety area

Ref	Product description
26204	100 x 200 x 20cm velcro
26205	200 x 200 x 20cm velcro
26216	240 x 200 x 20cm velcro
26217	300 x 200 x 20cm velcro
26218	400 x 200 x 20cm velcro

Replacement covers made to measure on request  
+33 1 64 40 05 70 or [info@dimasport.fr](mailto:info@dimasport.fr)



## FULLY ASSEMBLING DUAL DENSITY REVERSIBLE MATTRESS

Fitted with wide Velcro flaps (stitched along length and width) for wider versatility.

Ref	Product description
26280	240 x 200 x 20cm velcro (l/w)
26285	300 x 200 x 20cm velcro (l/w)

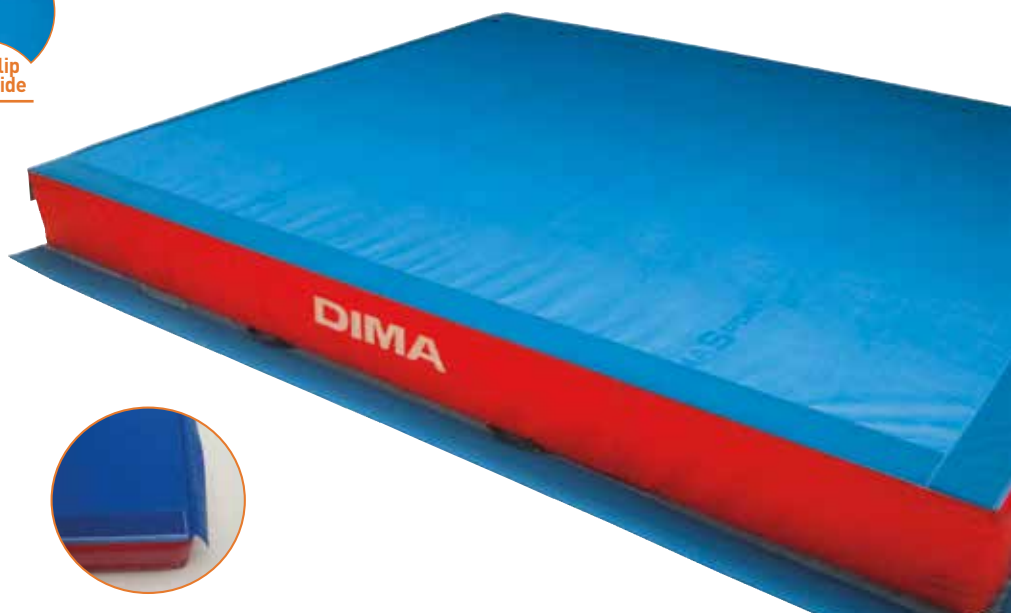
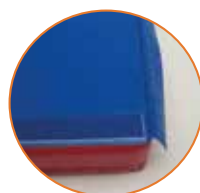

# GYMNASTICS



**MADE IN**  
OUR FACTORY  
IN PARIS REGION

## Made of:

- High quality polyurethane foam covered with 1000 denier flame-retardant M2 certified Tergal fabric.
- Leather grain surface and non-slip underside and an air-escape grid all around the mattress for a softer landing. Zip fastening on 3 sides.
- Non-tear handles with 8 stitch points **into the thickness of the mattress** allowing for easier transportation.

**FOLDING MATTRESSES**

Our folding safety mattresses are inseparable in order to take up less space and be easily transportable and storable (can stand up against a wall). Non-tear assembly of mattress components using seatbelt-type straps.

**DIMA EXTRAS**



These models have been specifically designed for intensive use in a collective environment. Compliant with safety standard NF EN 12503.

**5** year guarantee



## 2-PIECE FOLDING MATTRESS

Ref	Product description
23197	200 x 100 x 10cm (folded 100 x 100 x 20cm)
23198	240 x 200 x 20cm (folded 120 x 200 x 40cm)
23199	400 x 200 x 20cm (folded 200 x 200 x 40cm)

Replacement covers on request  
+33 1 64 40 05 70 or info@dimasport.fr



## 3-PIECE FOLDING MATTRESS

Ref	Product description
23250	300 x 200 x 20cm (folded 150 x 200 x 40cm)
23200	400 x 200 x 20cm (folded 200 x 200 x 40cm)
23210	500 x 200 x 20cm (folded 250 x 200 x 40cm)

Replacement covers on request  
+33 1 64 40 05 70 or info@dimasport.fr



**LANDING BLOCKS**

These versatile items can be combined in different ways using Velcro straps to make safe landing areas.

Multi-purpose: underneath equipment, landing from apparatus, landing from a trampette or attached together to make a high jump landing system.

Ref	Product description
15900	200 x 100 x 40cm
15905	200 x 100 x 50cm
15910	250 x 120 x 50cm
15920	250 x 150 x 50cm



**LANDING BLOCK REPLACEMENT COVER**

Ref	Product description
16000	200 x 100 x 40cm
16005	200 x 100 x 50cm
16010	250 x 120 x 50cm
16020	250 x 150 x 50cm

**HORIZONTAL TRANSPORTATION CART FOR MATTRESS AND LANDING SYSTEM**

Wooden deck mounted on a solid metal framework with 4 wide non-marking castors including 2 swivelling.

Maximum load 400kg.

Ref	Product description
22351	250 x 122cm



**TRAMPETTE**

Frame made from steel tubing, measurements 113 x 113cm. Adjustable angle. Non-slip feet. Pre-stressed nylon fabric mesh, 60 x 60cm. Foam frame guard. Transportation wheels fitted.

Ref	Product description
16230	Trampette with bungee cords
16235	Trampette with springs



**SPARE PARTS:**

Ref	Product description
16230020	Frame guard
16230025	Set of 32 springs
16230030	Mesh 60 x 60cm
16230040	Bungee cord – sold by set.

Ref 16230



Ref 16235

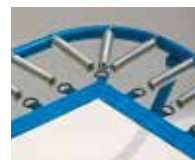

**DIMA+ EXTRAS**  
 FITTED WHEELS  
 Making for easier trampette handling.

# GYMNASTICS



Folding feet



Tightening snaplocks and thumbscrews



Rollers



## FREE-STANDING UNEVEN BARS FOR TRAINING

Easy adjustment of bar spacing (0.50 - 1.40m) and height using sliding tubes with snaplocks and thumbscrews (low bar from 140 to 165cm, high bar from 190 to 240cm) (fitted with springs for total safety)

Bars made of fibre glass covered with wood.

Higher upright reinforced with a brace for maximum safety.

Ref	Product description
24161	With fixed base
24166	With fixed base and rollers
24168	With folding base and rollers

(Additional anchor weights for base, on request)

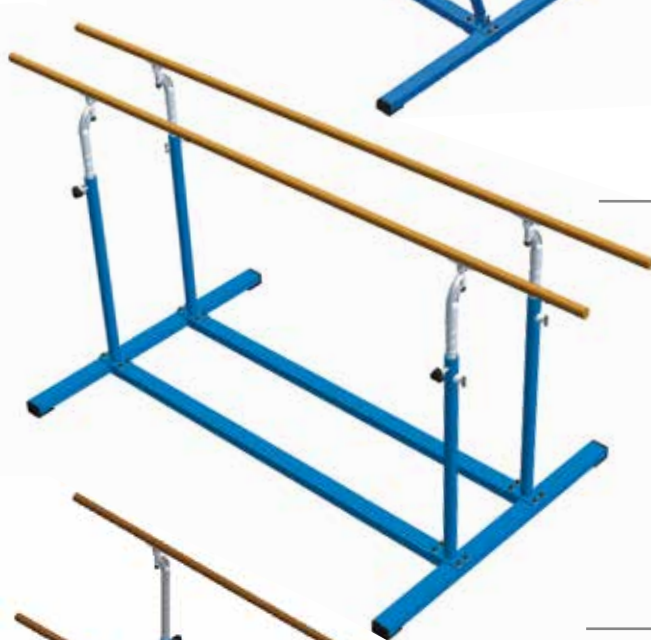

## FREE-STANDING PARALLEL BARS FOR TRAINING

On a heavy and stable base, 3.50m plywood rails, spacing adjustable from 33 to 65cm. Height adjustable from 140cm to 210cm using snaplocks and thumbscrews, with springs for total safety. Non-slip feet. Parts made from aluminium.

Ref	Product description
24151	With fixed base
24153	With fixed base and rollers
24156	With folding base and rollers (Additional anchors for base, on request)

## FREE-STANDING MIXED BARS

Bars allowing for dual use: as uneven or parallel bars.

High bar adjustable from 150 to 235cm. Low bar adjustable from 130 to 185cm with springs for total safety. Bar spacing from 39 to 65cm.

Ref	Product description
24171	With fixed base
24172	With fixed base and rollers
24176	With folding base and rollers

## APPARATUS ACCESSORIES

Ref	Product description
20020	Apparatus transportation cart (sold by pair)
ROULPARA	Rollers for parallel and mixed bars (sold by pair)
ROULASY	Rollers for uneven bars (sold by pair)
24164	Bar for uneven bars (sold individually)
24152	350cm bar for parallel and mixed bars (sold individually)

ROULASY/ ROULPARA



Ref 20020





## BARS WITH INTEGRATED MATTRESS

Ideal for the quick installation and removal of a gym floor.

Mattress: **Certified compliant with safety norm NF-EN 12503**, adaptable on Dima bars, with cut-outs for the uprights. **Folds away and fixes onto bars with wide Velcro flaps.**

Made from polyurethane foam 21kg/m<sup>3</sup>, covered with a leather grain finish phthalate-free 1000 denier tergal fabric and non-slip underside. Zip fastenings on 3 sides, **8 handles.**

For ease of use, **it is necessary to use the folding mattress combined with an apparatus fitted with rollers.**

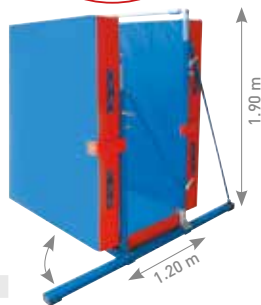
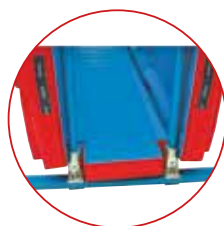

## FREE-STANDING UNEVEN BARS FOR TRAINING WITH MATTRESS

Mattress size 420 x 240 x 20cm

Ref	Product description
24195	Full set mattress + uneven bars with rollers
24196	Full set mattress + uneven bars with rollers + folding base.
24169	Folding mattress for uneven bars 420 x 240 x 20cm

## FREE-STANDING PARALLEL BARS FOR TRAINING WITH MATTRESS

Mattress size 450 x 250 x 20cm

Ref	Product description
24185	Full set mattress + parallel bars with rollers
24186	Full set mattress + parallel bars with rollers + folding base
24157	Folding mattress for parallel bars 450 x 250 x 20cm

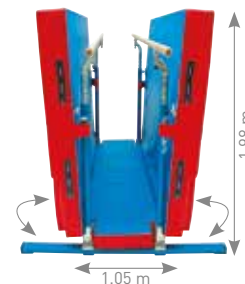

## FREE-STANDING MIXED BARS WITH MATTRESS

Mattress size 450 x 250 x 20cm

Ref	Product description
24190	Full set mattress + mixed bars with rollers
24191	Full set mattress + mixed bars
24157	Folding mattress for mixed bars 450 x 250 x 20cm



## FOAM TRAINING ITEMS

Ref	Product description
22200	Maxi platform n°6 170 x 70 x 100cm
24250	Platform 120 x 50 x 70cm
22320	4-level platform 160 x 60 x 120cm
22321	3-level platform 160 x 60 x 100cm

See Pedagogym, pages 12-13-14-15.

# GYMNASTICS



MADE BY  
**DIMA**

5 year  
guarantee

## SCHOOL BEAM

Non-deforming aluminium section body wall thickness 5mm for extra rigidity. Landing surface protected by 5mm of foam to avoid bumps, covered with special non-slip synthetic hide. Easy height adjustment from 90 to 140cm with a dual safety mechanism: snaplocks and thumbscrews. Zinc plated and stable feet fitted with non-marking rubber pads.

Ref	Product description
21625	Length: 5 metres. Adjustable height 90 – 140cm

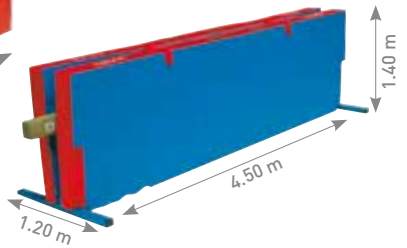

## SCHOOL BEAM WITH MATTRESS

Well-designed from both a sporting and a storage perspective, this full set is easy to install and put away in a small space.

Mattress: **Certified compliant with safety norm NF-EN 12503**, with cut-outs to adapt to Dima beams. Made from high quality polyurethane foam, covered with a 1000 denier flame-retardant M2 tergal fabric. Leather grain finish and non-slip underside. Phtalate -free removable cover with zip fastenings on 3 sides. **Fitted with wide Velcro flaps for easy attachment in folded position.**

**8 non-tear handles with 8 stitch points** allowing for easier transportation.

Mattress size: 450 x 260 x 20cm.

Ref	Product description
24180	Full set school beam + transportation carts + mattress
21627	Folding mattress for school beam 450 x 260 x 20cm



Ref 20020

Ref 21622

Ref 21623

Ref 21660

## BEAM ACCESSORIES

Ref	Product description
20020	Apparatus trolley (sold by the pair)
21622	Handling dolly (sold in pairs)
21623	2 replacement rollers
21660	Synthetic leather cover (2.50m)
21661	PVC cover (2.50m)
21550	Synthetic leather beam covering (5m)



## EXERCISE BARS

Uprights made of cylindrical painted steel diameter 90mm. Posts are tightened into sheaths manually. Horizontal bars made of stainless steel diameter 28mm adjustable from 0.60 to 2.50m with graduated clips (8 holes every 20cm in lower part and 5 holes every 10cm in higher part). Spacing between poles: 2.40m.

Ref	Product description
70085	Exercise bars (1 bar)
70086	Exercise bars (2 bars)
70087	Exercise bars (3 bars)

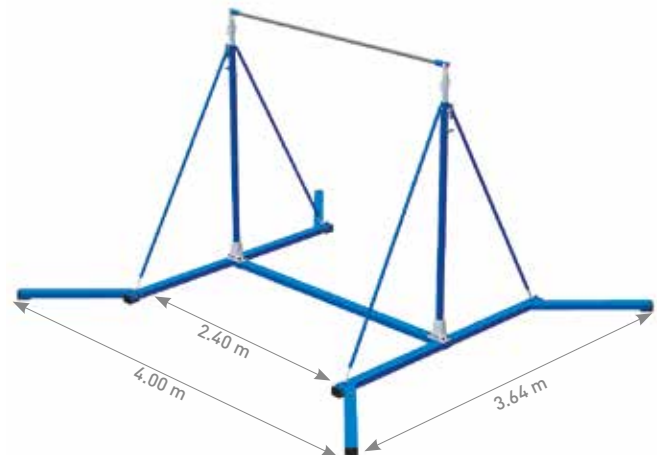

## UNSS HIGH BAR

Cable-free high bar, set on heavy base with safety spread feet and inbuilt anchor weights. Bar is height adjustable from 215 to 285cm every 5cm. Flexible bar made from treated steel. Double bar blocking mechanism: thumbscrews and snaplocks. Bases fitted with non-marking rubber pads.

Ref	Product description
20161	UNSS high bar Footprint: 4.00 x 3.64m.



**FOAM BEAM**

Both educational and safe to use, the foam beam is ideal for starting out and learning new movements. Made from dense polyethylene foam covered with a 1000-denier leather finish flame-retardant M2 fabric. Upper side special synthetic leather and underside, both non-slip. **Base width 30cm – Beam width 10cm – Height 15cm.**

Ref	Product description
24035	Foam beam 2m
24030	Foam beam 3m



**LOW BEAM**

Aimed at clubs and schools, this beam is ideal for beginners.

Non-deforming aluminium section body wall thickness 5mm for extra rigidity. Landing surface protected by 5mm of foam to avoid bumps, covered with a 1000-denier leather grain finish flame-retardant M2 fabric. Feet fitted with non-marking rubber pads. **Height : 30cm.**

Ref	Product description
21640	Low beam length 360cm
21650	Low beam length 500cm



**MADE UP OF 3 BEAMS REF. K2032**

**ZIG ZAG BEAM**

Ref	Product description
K2032	ø120 x 20 x h 20cm (1 module)
K2032X3	Set of 3 zig-zag beams



Ref 22326



Ref 22325

**WOODEN VAULTING PLATFORM**

Ideal for school and club use.

Made from glue-laminated wood, the top module is cushioned, with a leather grain finish top. The apparatus is easy to move thanks to integrated and foldaway rollers for total safety. This platform is very robust and can be used frequently by groups.

Ref	Product description
22326	Pyramid platform with rollers (L.140 x w.75/40 x h.110cm) (4 modules 20cm + 1 module 30cm)
22325	Straight sided platform with rollers (L.150 x w.50 x h.110cm) (4 modules 20cm + 2 modules 10cm)



**TRAINING SPRINGBOARD**

Ideal for use in schools and clubs.

Measurements (L x w x h) 120 x 65 x 15cm  
Made of plywood with carpet surface. This springboard is very robust and can be used frequently by groups.

Ref	Product description
22101	Training springboard



**COMPETITION SPRINGBOARD**

Ideal for competition use and in schools and clubs.

Measurements (L x w x h) 120 x 60 x 21cm  
Made of plywood with extra-cushioned carpet surface to avoid fatigue injury. This springboard is very robust and can be used frequently by groups.

Ref	Product description
22102	Competition springboard



**DOUBLE CLUB SPRINGBOARD**

Ideal for use in clubs and competition

Measurements (L x w x h) 120 x 60 x 21cm  
Made of plywood and springs for more energy return. Carpet surface. This springboard is very robust for very regular use in clubs.

Ref	Product description
22103	Double club springboard

# GYMNASTICS



## PRIMA GYM APPARATUS

Ideal for beginner gymnastics and body coordination for young children. Well-suited and stable. Sturdy, safe and light equipment, no adjustments necessary. Bars made from fibre glass. Apparatus supplied with free indoor protection mat.



### PRIMA PARALLEL BARS

Ref	Product description
24000	Footprint 0.76 x 1.76m Bar height: 88cm; Spacing: 40cm



### PRIMA UNEVEN BARS

Ref	Product description
24010	Fixed and non-adjustable bar heights: 0.84 and 1.40m Footprint: 0.76 x 1.76m



### PRIMA HIGH BAR

Ref	Product description
24020	Height: 1.60m Footprint: 2.00 x 1.50m

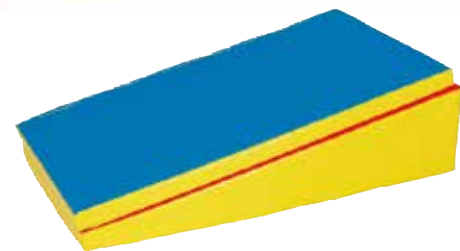

### SOMERSAULT MAT

Ref	Product description
KB013207	200 x 60 x 25 / 5cm Measurements folded: 100 x 60 x 30cm



### BABY TRAMPOLINE

Bouncy and safe, this baby trampoline is designed for play and learning.

Steel tube frame. Non-slip rubber feet. Supplied with foam frame guard.

Ref	Product description
K3075	155 x 115 x 32cm
K3076	Double 220 x 90 x 20cm



### THREE FOLD MAT

Ref	Product description
KB013106	180 x 60 x 4cm Measurements folded 60 x 60 x 12cm



### ELEPHANT SLIDE FOAM

Designed for group use.

Ref	Product description
K3045	Dimensions 200 x 65 x 60cm



### BOABEAM FOAM

Designed for group use.

Ref	Product description
K3080	Dimensions : 250 x 20 x 20cm



### BABYCLIMB FOAM

Triangular block on which 6 different shaped holds are attached using Velcro strips.

Ref	Product description
K3005	Dimensions 150 x 70 x 50cm
KB021003	Dimensions 96 x 48 x 24cm



Ref 30300 (optional mat)



Ref 30310 (Optional mat)



Ref 30400 (Optional mat)



Ref 30500



Ref 30110



A teaching and motor skill / agility tool, the Gymkid range offers a wide spectrum of shapes and colours to build environments for discovery, adventure and risk-taking.

The foam modules **fix together** using wide Velcro patches on all sides, allowing an **infinite** number of combinations.

Ideal for agility exercises and play in total safety

5 year guarantee

**DIMA+**  
**EXTRAS**

- Washable
- 24kg/m<sup>3</sup> foam modules covered on 650gm fabric
- Phtalate-free
- Flame-retardant M2

**30110 - CLIMBING WALL (3 MODULES)**

Ref	Product description
30020	1 red broken wedge 150 x 60 x 60cm
30030	1 blue incline 150 x 60 x 60cm
30050	1 set of 5 holds L=60cm

**30110**

**30310 - MINI GYM KID (5 MODULES)**

Ref	Product description
30180	1 small tower with Velcro 60 x 60 x 75cm
30150	1 Velcro cage 75 x 60 x 60cm
30050	1 set of 5 Velcro holds L = 60cm
30170	1 Velcro tobogym 150 x 90 x 60cm
30020	1 red Velcro pedago broken wedge 150 x 60 x 60cm

**30310**

**30300 - GYM KID (7 MODULES)**

Ref	Product description
30180	1 small tower with Velcro 60 x 60 x 75cm
30150	1 Velcro cage 75 x 60 x 60cm
30050	1 set of 5 Velcro holds L = 60cm
30170	1 Velcro tobogym 150 x 90 x 60cm
30020	1 red Velcro pedago broken wedge 150 x 60 x 60cm
30030	1 blue Velcro pedago incline
30210	1 Velcro staircase 100 x 60 x 50cm

**30300**

**30400 - GYM KID PLUS (14 MODULES)**

Ref	Product description
30180	1 small tower with Velcro 60 x 60 x 75cm
30150	1 Velcro cage 75 x 60 x 60cm
30050	2 sets of 5 Velcro holds L = 60cm
30170	2 Velcro tobogyms 150 x 90 x 60cm
30020	1 red Velcro pedago broken wedge 150 x 60 x 60cm
30030	1 blue Velcro pedago incline 150 x 60 x 60cm
30210	1 Velcro staircase 100 x 60 x 50cm
30190	1 large tower with Velcro 60 x 60 x 150cm
30010	3 blue pedago blocks 150 x 60 x 60cm
30010010	1 special pedagogym half block

**30400**

**30500 - SUPER GYM KID (17 MODULES)**

Ref	Product description
30180	1 small tower with Velcro 60 x 60 x 75cm
30150	1 Velcro cage 75 x 60 x 60cm
30050	2 sets of 5 Velcro holds L = 60cm
30170	2 Velcro tobogym 150 x 90 x 60cm
30020	2 red Velcro pedago broken wedges 150 x 60 x 60cm
30030	2 blue Velcro pedago inclines 150 x 60 x 60cm
30210	1 Velcro staircase 100 x 60 x 50cm
30190	1 large tower with Velcro 60 x 60 x 150cm
30010	4 blue pedago blocks 150 x 60 x 60cm
30010010	1 special pedagogym half block

**\* 30500**

# GYMNASTICS



What could be more natural for a child than to **run, jump, throw, crawl** and develop its motor skills and agility in **total safety**? Dima deploys all of its expertise as a designer and manufacturer and its creativity for the benefit of the youngest children, offering you well-suited, versatile, scalable and fun-to-use courses. To play in total safety without ever getting bored, our modules are adaptable and adjustable with Velcro, guaranteeing faultless safety in its various configurations.

Designed for  
collective use

**DIMA+**  
**EXTRAS**

- Washable
- 24kg/m<sup>3</sup> foam modules covered with 1000 denier Tergal fabric
- Special non-slip surface



## K3580 - LITTLE DEVIL COURSE

Ref	Product description
K2020	6 x 60° Corner mats, diam. 180cm
K2040	1 Beam 120 x 30 x 30cm
K2056	1 Half-cylinder diam. 30 - 60 x 15cm
K2057	1 Half-cylinder diam. 50 - 60 x 25cm
K2081	2 x 6-circuit square centres 60 x 50cm
K2100	2 Square beam supports 30 x 60 x 40cm
K2107	1 Gymbumps 120 x 45 x 40/20cm
K2113	1 Tower 60 x 60 x 75
K2132	2 Waves 45 x 60 x 40/30cm
K2133	1 Wave 90 x 60 x 40cm
K2141	1 Staircase 3 steps 70 x 60 x 50cm
K2159	1 Wavy incline 90 x 60 x 50cm
K2174	1 Flat incline 120 x 60 x 50cm
K2193	1 Cage 60 x 60 x 75cm

K3580

## K3570 - NOT SCARED COURSE

Ref	Product description
K2005	1 Cube 60 x 60 x 7cm
K2009	1 Block 40 x 40 x 20cm
K2020	6 x 60° Corner mats, diam. 180cm
K2048	1 Cylinder diam 30 - 120cm
K2056	1 Half-cylinder diam. 30 - 60 x 15cm
K2057	1 Half-cylinder diam. 50 - 60 x 25cm
K2081	2 x 6-circuit Square centres 60 x 50cm
K2094	2 Supports for cylinder 30 x 60 x 40cm
K2107	1 Gymbumps 120 x 45 x 40/20cm
K2141	1 Staircase 3 steps 70 x 60 x 50cm
K2159	1 Wavy incline 90 x 60 x 50cm
K2174	1 Flat incline 120 x 60 x 50cm
K2197	1 Platform 120 x 60 x 30cm

K3570

## K3525 - COWBOY COURSE

Ref	Product description
K2005	1 Cube 60 x 60 x 7cm
K2018	4 x 90° Corner mats, diam. 180cm
K2048	1 Cylinder diam 30 - 120cm
K2094	2 Supports for cylinder 30 x 60 x 40cm
K2132	1 Wave 45 x 60 x 40cm
K2133	1 Wave 90 x 60 x 40cm
K2140	1 Staircase 3 steps 60 x 60 x 30cm

K3525

## K3460 - RESOURCEFULNESS COURSE

Ref	Product description
K2001	1 Cube 45 x 45 x 20cm
K2017	2 x 90° Corner mats - diam. 120cm
K2064	1 round pouf diam 40 / 20cm
K2088	1 Tunnel 150 x 60 x 60cm
K2106	1 Gymbumps 120 x 45 x 40/20cm
K2139	1 Staircase 2 steps 40 x 45 x 20cm
K2155	1 Wavy incline 60 x 45 x 20cm hollow
K2156	1 Wavy incline 60 x 45 x 20cm bumps
K2171	1 Flat incline 60 x 45 x 20cm

K3460



## K3555 - BIG BALANCING COURSE

Ref	Product description
K2040	1 Square beam 120 x 30 x 30cm – red and blue
K2048	1 Cylindrical beam diameter 30 x 120cm – red and blue
K2064	1 Round pouf diam 40 x 20cm – red and blue
K2065	1 Round pouf diam 40 x 30cm –blue and grey
K2066	1 Round pouf diam 40 x 40cm – green and yellow
K2094	2 Supports for cylinder 30 x 60 x 40cm
K2100	2 Supports for square beam 30 x 60 x 40cm
K2133	1 Wave 90 x 60 x 40cm
K2180	1 Flat incline 180 x 120 x 40cm
K2197	1 Platform 120 x 60 x 30cm

## K3575 – INFERNAL COURSE

Ref	Product description
K2018	4 x 90° Corner mats, diam. 180cm
K2020	6 x 60° Corner mats, diam. 180cm
K2040	1 Beam 120 x 30 x 30cm
K2048	1 Cylindrical beam diameter 30 x 120cm
K2087	1 Tunnel 75 x 60 x 60
K2088	1 Tunnel 150 x 60 x 60cm
K2094	2 Supports for cylinder 30 x 60 x 40cm
K2100	2 Supports for square beam 30 x 60 x 40cm
K2132	1 Wave 45 x 60 x 40/30cm
K2133	1 Wave 90 x 60 x 40cm
K2140	1 Staircase 3 steps 60 x 60 x 30cm
K2148	1 Toboslide 80 x 60 x 50cm

**K3555**

**K3575**

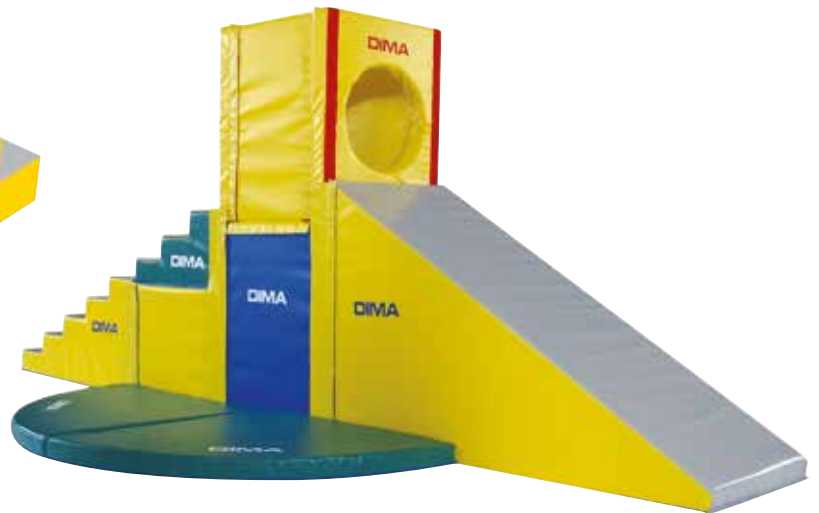
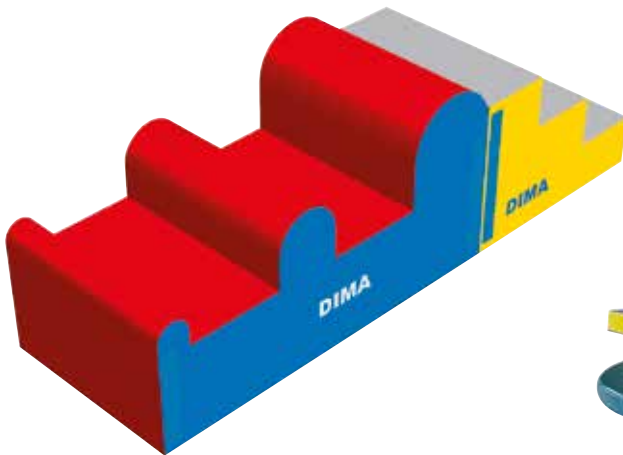

## K3485 – BIG BUMP COURSE

Ref	Product description
K2107	1 Gymbumps 120 x 45 x 40/20cm
K2141	1 Staircase 3 steps 70 x 60 x 50cm

**K3485**

## K3550 – MOUNTAINEER COURSE

Ref	Product description
K2003	1 Cube 60 x 60 x 50cm
K2018	4 x 90° Corner mats, diam. 180cm
K2113	1 Tower 60 x 60 x 75
K2140	1 Staircase 3 steps 60 x 60 x 30cm
K2141	1 Staircase 3 steps 70 x 60 x 50cm
K2149	1 Toboslide 150 x 60 x 90cm
K2193	1 Cage 60 x 60 x 75cm

**K3550**

# DIMASPORT

SPORTS EQUIPMENT

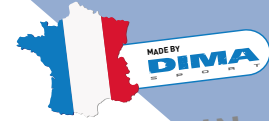

## MANUFACTURER

WE MANUFACTURE OUR PRODUCTS IN OUR FACTORIES NEAR PARIS.

### METALWORK

We cut, drill and weld the steel ourselves. Every production stage is rigorously controlled.



### OBOL WORKSHOP

Dima also makes throwing implements: discusses, hammers and javelins are manufactured in our factory.



### TARPAULINS

For over 50 years, we have been constantly improving our processing methods to offer top-quality products.



Dima is the only French company to make its own throwing implements.

### RAW MATERIALS



Our foams are of the highest quality and we know their composition.



Our canvases are inspected and certified.



We select our steels carefully and we know where they come from.

We require unremittingly high standards from our suppliers, because the quality of our raw materials largely guarantees the quality of our products.

Foam is a costly but fundamental component in our products; we are constantly attentive to its quality and make no compromises.

RESPONSIBLE FOR PRODUCTION  
TO FULFIL **YOUR SATISFACTION**  
TOTAL COMMITMENT FROM DIMA





## DIMA, INVENTOR OF SPORTS EQUIPMENT

### CREATOR

CLOSE TO GRASS-ROOTS NEEDS, WE REMAIN ATTENTIVE TO YOUR REQUIREMENTS AND REGULARLY BRING OUT NEW PRODUCTS.

The inventors of the folding high jump landing system, with in particular the now renowned platform mounted foldaway (created in 1975), inventor of school PE hurdles (created in 1975), etc.

In this section you will discover even more new products.

## CONTENTS

# ATHLETICS

<b>RUNNING</b>	Stopwatches.....	34
	Measurement.....	35
	Small equipment.....	36
	Starting blocks.....	38
	Hurdles.....	39
<b>THROWING</b>	Shot put.....	44
	Hammers.....	45
	Discuses.....	46
	Measurement.....	46
	Throwing targets.....	48
	Javelins.....	49
<b>JUMPING</b>	High jump.....	50
	Pole vault.....	54
	Poles.....	56
	Pole Vault Packs.....	58
	Sheds.....	59
<b>ATHLETICS PLAY</b>	.....	
	Athletics packs.....	60
	School and teaching equipment.....	61



### CASE OF 24 DIGI DT1 STOPWATCHES

A set of 24 DIGI stopwatches supplied in a sturdy red case certified DIGI SPORT INSTRUMENTS with foam compartments for safe and tidy storage.

Measurements: 330 x 240 x 80 mm

DT1 stopwatch product features:

12 or 24 hour format (h, min, sec), Accurate to 1/100th second with split times, date and alarm, push button controls, splash-proof.

Ref	Product description
15525	Set of 24 DIGI DT1 stopwatches



### BASIC STOPWATCH

Simple time + addition, Split time, Capacity: 24h to 1/100th second up to 30 minutes, Calendar / Alarm / Clock, Measurements 80 x 57 x 24 mm / 80 g – Battery 357 / battery protector tab.

Ref	Product description
15534	Basic stopwatch



### MULTI-FUNCTIONAL STOPWATCH

Accurate to 1/100th second. (up to 30 minutes), 1 display line, single timings, alarm, start/stop buzzer, time/ calendar.

Ref	Product description
15521	Multi-Functional stopwatch



### COACH STOPWATCH

10 hour timing to 1/100th second, 60 timings / Split or Lap, memory of Split or Lap times, simple timer up to 10 hours to the second, indication of number of cycles, repeatable up to 199 times, audible or silent start and stop, thermometer, 12 or 24 hour clock, calendar, alarm (wake-up) for 30 seconds, backlighting 5 seconds, waterproof to 1 ATM (splash-proof).

Ref	Product description
15532	Coach stopwatch



### TRAINER STOPWATCH

Practical and accurate to 1/100th second (up to 30 minutes). 2 display lines, 20 timings memory, single timings, stats, splits (intermediate times), laps (lap by lap), Countdowns, 24 hour capability, alarm.

Ref	Product description
15522	Trainer stopwatch



### MAJOR STADIUM STOPWATCH

Accurate to 1/100th second. (up to 30 minutes), 3 display lines, 100 timings memory, single timings, timings addition, splits, stats, laps, lap counter, calendar, alarm. Watertight.

Ref	Product description
15523	Major Stadium stopwatch



### PRO SOLAR STOPWATCH

10 hour timing to 1/100th second, 30 timings / Split or Lap, simple timer up to 10 hours to the second / beep for last five seconds, indication of number of cycles, repeatable up to 99 times, audible or silent operation (except countdown timer) time statistics: longest, shortest, average, temperature / humidity / dew point / heat index, 12/24 hour clock, calendar, alarm (wake-up) for 30 seconds, backlighting 5 seconds, ABS shockproof casing, waterproof to 1 ATM (temporary surface immersion), powered by solar cells.

Ref	Product description
15529	Pro Solar stopwatch

Ref 15531

Ref 15526



### DT 2000 STOPWATCH & PRINTER

Stores up to 500 split and lap times with possibility of print-offs (optional printer). Accurate to 1/100th second up to 10 hours. Memory file according to event. Displays split / lap times / speed. Calculates speed from selected distance. Countdown timer. Audible pacer. Water resistant.

Ref	Product description
15531	DT 200 stopwatch
15526	Printer for DT 2000 stopwatch



### DIGI DT 2500 P STOPWATCH PRINTER

2,000 entry memory, display of average and best lap times, automatic publication of lap time after 10 seconds to monitor progress, stopwatch locking button to prevent handling accidents, double timer which start at the same time during training, possibility of using conventional countdown timer if 2nd timer is not in use, hours, minutes, seconds, month, date, day and wake-up alarm.

Ref	Product description
15528	DT 2500 P stopwatch



### SEIKO WRIST STOPWATCH S23571

Integrated printer. Up to 10 hours, 300-entry memory, 3-line display. Times and calendars. Supplied with rolls.

Ref	Product description
15527	Seiko Wrist stopwatch S23571



### FIBRE GLASS MEASURING TAPE

Flexible and tear-resistant

Ref	Product description
11500	10 m
11510	20 m
11520	30 m
11522	50 m with Handle
11525	100 m with Handle



### SECTION BANNERS

Ref	Product description
90000	50 m Section Banner
90001	Banner Fixing Post (Set of 10)
14360	Banner Blocks (per unit)



### PEDOMETER

Step distance from 10 to 215 cm / +- sensitive. Counts up to 99,999 steps. Clock function. Battery: LR44 (included)  
Measures: 55 x 50 x 35 mm / 26g

Ref	Product description
11641	Pedometer



### STEEL MEASURING TAPE

I.A.A.F Approved. Openwork Case, in Aluminium Alloy

Ref	Product description
11430	10 m
11440	20 m
11450	30 m
11470	30 m with Handle
11480	50 m with Handle
11490	100 m with Handle



### MEGAPHONE

Outdoor or indoor usage. Battery powered (not supplied)

Ref	Product description
10600	Megaphone range 400 m
10601	Range 1,000 m



### DISTANCE MEASURING WHEEL

Larged numbered counter in the middle for better balance. Easy resetting to zero. Backward measuring. Foot brake. Foldable sleeve. Support leg. Capacity: 10km. 1 metre wheel circumference, ø318 mm. 2.1 kg. weight.  
Delivered with a transportation bag.

Ref	Product description
11640	Distance Measuring Wheel

# ATHLETICS

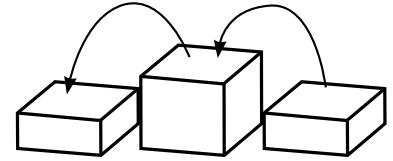

**3 PLACE AWARDS STAND/STACKING PLINTHS**  
 Made from painted wood. Non-slip carpeted surface. The three blocks fit inside each other for compact storage. Equipped with handles for easy transportation. 2 blocks measuring 60 x 46.5 x 25 cm and 1 block measuring 53 x 55 x 50 cm. Storage space required: 63 x 53 x 55 cm

Ref	Product description
10883	3 place awards stand/stacking plinths



## DIMA OFFICIAL'S CLIPBOARD

Clipboard printed with track indication marks, useful for protecting your paperwork and find your bearings on an athletics track (relay exchange zones, height and position of hurdles, throwing implement weights by category, etc.).

Ref	Product description
10820	Dima official's clipboard



## WHISTLES

Ref	Product description
10510	Set of 3 plastic whistles with lanyard
10511	Hygienic handheld whistle. Sold by the unit.



## START CLAPPER BOARD

Made of two wooden arms with handles and two semicircles coloured white and red.

Ref	Product description
10500	Start clapper board
10501	Wooden clapper board



## RELAY BATONS

Set of 6 PVC relay batons (diameter 39 mm, length 29.5 cm)

Ref	Product description
10181	Set of 6 Plastic Batons - ø 39 mm. Length 29.5 cm
10180	Set of 4 Aluminium Batons - ø 38.5 mm. Length 29.5 cm - Approved.



## VINYL TAPE

Usable indoors and outdoors to mark play and work areas. Can be cut to make stride indicators. Composition: In soft PVC. 4 cm. width.

Ref	Product description
10373	Vinyl Tape 10 m
10374	Vinyl Tape 20 m

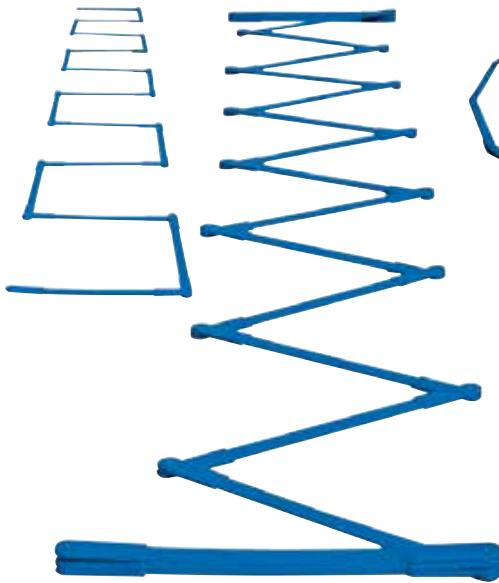

**AGILITY LADDER**

Allows for organisation of space and the programming of rhythm exercises. Flexible spacing. Very easy to position. Lightweight and easy to use. Made from anti-slip rubber. Rung lengths 43 cm. Supplied with free storage bag.

Ref	Product description
10381	12m agility ladder



**HOOP LADDER**

Running, jumping, the hoop ladder facilitates the organisation of space and plan rhythm exercises. Comprising 12 flat hoops of 50 cm diameter. Delivered with free storage bag.

Ref	Product description
K5205	Hoop ladder



**AGILITY HOOP LADDER**

Comprised of 8 x 60 cm. rods, 12 x 60 cm diameter round hoops and 12 clips. Delivered with a free storage bag.

Ref	Product description
K5206	Agility hoop ladder



**FOOT SPEED LADDER**

Length: 8.50 m. Width: 50 cm. Possibility to join up several ladders using an attachment system. Adjustable spacing. Delivered with a free storage bag.

Ref	Product description
10377	8.5 m Climbing Ladder



**METRIC TAPE**

In unwoven fabric. Very light and easy to position. 17 cm.wide. Markings every 20 cm.

Ref	Product description
10390	20 m. Tape
10395	50 m. Tape



**STRIDE INDICATOR**

Aimed at working on rhythm by placing the bands at regular intervals according to athlete's stride. Made of anti-skid rubber. Colour-marked both sides, 42.5 x 3.5 cm

Ref	Product description
10372	Set of 20 stride indicators



## BEGINNER STARTING BLOCKS

Made from hard rubber, ideal for learning starts.

Ref	Product description
10112	Set of 2 blocks

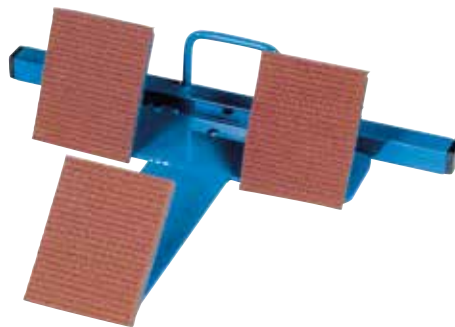

## TRIPOD STARTING BLOCKS

Ideal for athletics coaching associations and schools.

**Placed down or fixed (pin) with a handle.** Comprised of 3 fixed blocks (1 in front, 2 at the back) covered with a synthetic cover. Very quick to use. No right-hand or left-hand adjustment.

Ref	Product description
10117	Tripod starting blocks

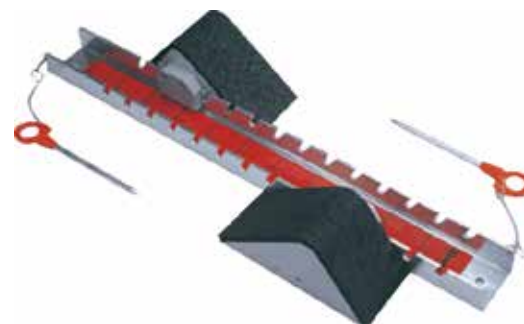

## SCHOOLS STARTING BLOCKS

Ideal for schools and athletics coaching associations. 14 adjustment options.

Ref	Product description
10113	Schools Starting Blocks

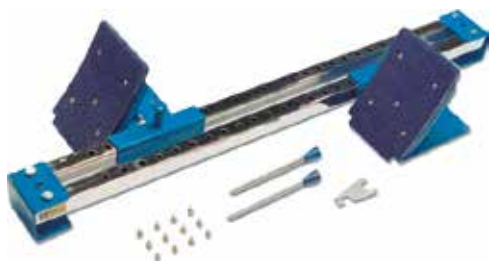

## PE STARTING BLOCKS

Lightweight model with a double bar for multiple adjustments. Blocks covered in PVC pads. Fixings for a synthetic or cinder track.

Ref	Product description
10120	PE Starting Blocks



## TRAINING STARTING BLOCKS

**Nice-looking model, stable and highly technical. Excellent quality/price balance.**

Central arm in extruded aluminium, very rigid. 16 adjustment markings plus 4 block angle adjustments. PVC pads.

Ref	Product description
10116	Training Starting Blocks



## COMPETITION STARTING BLOCKS

**I.A.A.F n° E-02-0340 IAAF Approved and certified.**

Nice-looking model, heavy, stable and highly technical.

Central arm in extruded aluminium, very rigid. Adjustment possible using markings on a wide rack plus 4 block angle adjustments. Blocks interchangeable with synthetic pads. Fixings for a synthetic or cinder track.

Ref	Product description
10114	Competition Starting Blocks

## SYNTHETIC TRACK ROLL

**Black, thickness 12 mm** (suitable for points)

Ref	Product description
13162	10 x 1.25m track roll
13163	Linear Metre

**Black, thickness 6 mm** (suitable for points)

Ref	Product description
13172	10 x 1.25m track roll
13173	Linear Metre

**Synthetic competition Mondo Mat, red, 12 mm thick**

Ref	Product description
13161	15 x 1.22m track roll
13160	Linear Metre



## SPECIAL START POWER SLED

For power exercises. Weighed down by 28 mm diameter cast iron disc (not supplied). Delivered with a 10-meter strap harness. Its shape allows it to straddle the starting blocks.

Ref	Product description
70016	Special start power sled

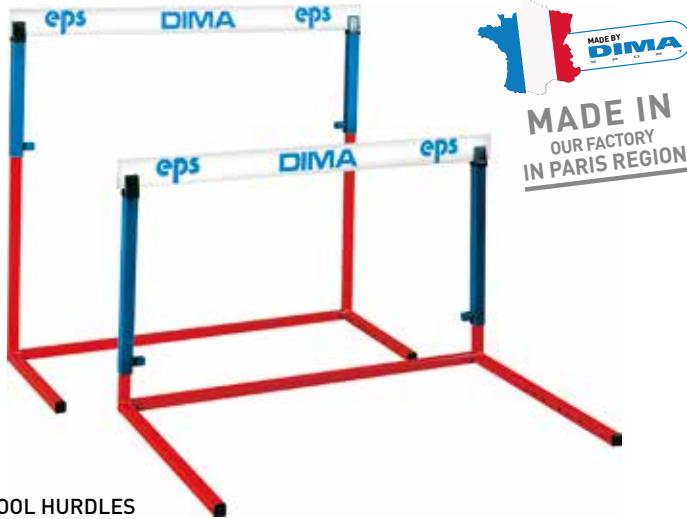

**SCHOOL HURDLES**

Genuine hurdles, perfect for beginners or footwork. Sturdy and easy to handle, Lacquered steel construction, supplied with protective rubber end pieces. The PVC hurdle board is set on rubber supports for greater safety and less apprehension. Automatic height adjustments using hidden ball plunger system. Heights: 55 - 60 - 65 - 70 - 76 - 84 - 91 - 96 - 99 - 106 cm - Width: 1m

Ref	Product description
10330	Set of 3 school hurdles
10336	Set of 6 school hurdles
10320011	Rubber support for school and mini hurdle boards
10380	Replacement hurdle board for school and mini hurdles

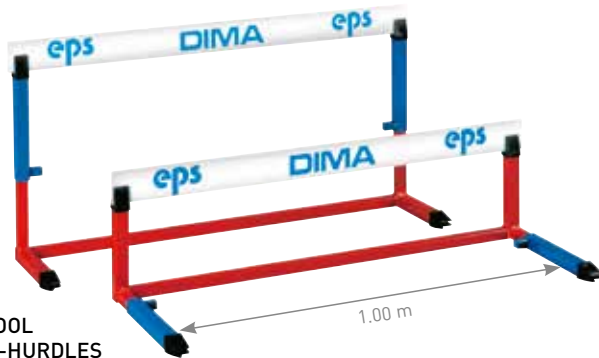

**SCHOOL MINI-HURDLES**

Same design as school hurdles. Height 28-35-40-45 cm

Ref	Product description
10230	Set of 3 school mini-hurdles
10236	Set of 6 school mini-hurdles
10320011	Rubber support for school and mini hurdle boards
10380	Replacement hurdle board for school and mini hurdles

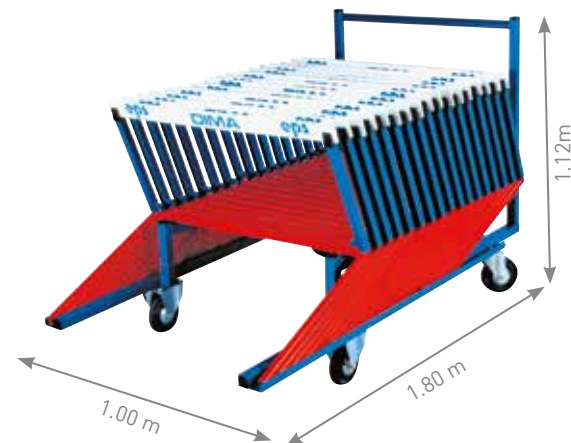

**SCHOOL HURDLE CART**

Lacquered steel, high quality manufacture. Easy to steer with its 4 multi-directional wheels.

Ref	Product description
10020	20 school hurdle cart: 180 x 100 x 112 cm
10021	30 school hurdle cart: 240 x 100 x 112 cm

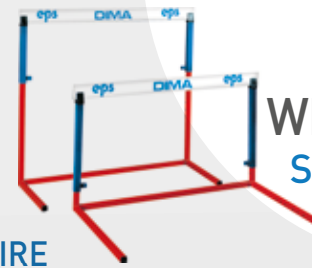

**TIPS**  
What to do with...  
**SCHOOL HURDLES**

Ref 10330, 10336

**ACQUIRE 2 APPROACH TECHNIQUES FOR MOVEMENTS "UPWARDS" OR "FORWARDS"**

**PISTON TECHNIQUE**  
FREE LEG BENT AND LOCKED  
**UPWARDS**



**PULL-PUSH TECHNIQUE**  
FREE LEG BENT-EXTENDED  
**FORWARDS**

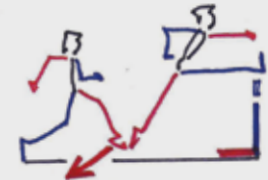

► The "upwards" drill (PH-2A) with two steps between hurdles. Identical hurdle heights and intervals



► The "forwards" drill (6H - 2A) identical height of 6 hurdles but intervals gradually increasing by 0.10 to 0.20 compared to previous interval.



**CHOOSE DIFFICULTIES TO SUIT YOUR ATHLETES... WHEN TEACHING A CLASS, offer three drills, A, B and C, increasing in difficulty.**

**MOTIVATION:** if you pass B, you can try C!

		► PH.2A			► 6H.2A		
		A	B	C	A	B	C
Age 10-12	Hurdle h.	0.28m	0.28m	0.35m	0.40 m	0.40 m	0.40 m
	Interval	1.50 m	1.80 m	2.00 m	2.20 m	2.35m	2.50 m
		A	B	C	A	B	C
Age 14-15	Hurdle h.	0.35m	0.40 m	0.56m	0.56m	0.65m	0.76m
	Interval	1.80 m	2.00 m	2.25m	2.50 m	2.80 m	3.00 m
		A	B	C	A	B	C
Age 17-18	Hurdle h.	0.56m	0.65m	0.76m	0.76m	0.84m	0.91m
	Interval	2.40 m	2.60 m	2.80 m	3.20 m	3.50 m	3.75m



## OFFICIAL HURDLE HEIGHTS

CATEGORY	MALE	FEMALE
Under elevens	50 m - 0.65m	50 m - 0.65m
Children	50 m - 0.65m	50 m - 0.65m
Minors	80 m - 0.84m	50 m - 0.76m
Minors	100 m - 0.84m	80 m - 0.76m
Minors	200 m - 0.76m	200 m - 0.76m
Cadets	110 m - 0.91m	100 m - 0.76m
Cadets	400 m - 0.84m	400 m - 0.76m
Juniors	110 m - 0.99m	100 m - 0.84m
Juniors	400 m - 0.91m	400 m - 0.76m
Seniors	110 m - 1.06m	100 m - 0.84m
Seniors	400 m - 0.91m	400 m - 0.76m



## SPECIAL EDUCATIONAL CLUB HURDLES

Hurdle ideal for training due to its lightness and no L-shaped supports. Allows lateral training without risk of sprains. Steel construction. Specifically developed for training groups. Adjustable heights: 65 - 76 - 84 - 91 - 99 - 106 cm. Instant height adjustments using a ball & spring system. PVC hurdle board.

Ref	Product description
10301	Special Educational Club Hurdle (set of 5)



## ELECTRO-GALVANISED CLUB HURDLES

Specifically for training. No counterweights. In steel with an anti-rusting electro-plating treatment, giving the product an exceptional shine increased lifespan. Adjustable heights: 65 - 76 - 84 - 97 - 99 - 106 cm. Bars fitted with protective rubber ends. Adjustment of hurdle height by ball and spring system. PVC hurdle board.

Ref	Product description
10300	Electrogalvanised Club Hurdle
10310	PVC Hurdle Board - I.A.A.F certified



DIMA TIPS

What to do with...  
FOAM HURDLE MATS

Ref 23936, 23941, 23946



HOPPING - JUMPING

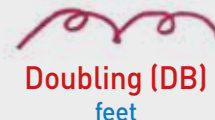

Run up 5m max

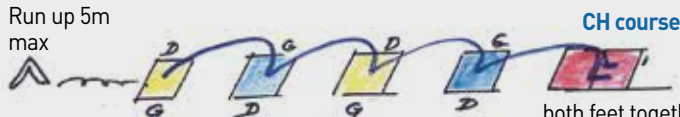

both feet together on long jump mat



When the next mat is a different colour, you change your landing foot; when the next mat is the same colour, you land with the same foot as before. Don't get them to all do the same course. Offer three different-difficulty courses: A, B and C. They can only do C if they get B right.

	CH COURSE			DB COURSE		
	A	B	C	A	B	C
Age 10-12	1m	1.25m	1.50 m	0,60 m	0,80 m	1m
Age 14-15	1.50 m	1.75m	2m	1.20 m	1.40 m	1.60 m

Distances expressed are between mat centres.

VARIATIONS

► Courses alternating between same-foot (DB) landings and opposite foot (CH) landings



► Mastering this will lead to an Olympic triple jump.

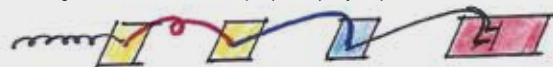

FOAM HURDLE MATS

Perfect for learning, this product provides total safety and eliminates any fears. Provided with end velcro strips, the assembly of these mats achieves a very flat surface (like a gym mat surface) for footwork, coordination, or gymnastic exercises. Made from polyurethane foam with PVC cover. Anti-slip underside. Thickness 4 cm

Ref	Product description
23936	Set of 4 folding hurdle mats 35 cm - Dim. unfolded: 100 x 70 cm
23941	Set of 4 folding hurdle mats 50 cm - Dim. unfolded: 100 x 100 cm
23946	Set of 4 folding hurdle mats 65 cm - Dim. unfolded: 100 x 130 cm



MINI OBSTACLES

Ideal for track work. Can be piled on top of one another. Polyurethane foam covered in a 1000 denier Tergal fabric. Delivered with a free storage bag.

Ref	Product description
10345	Set of 8 Red Mini Obstacles 50 x 12 x 12 cm
10346	Set of 8 Yellow Mini Obstacles 50 x 18 x 18 cm



FOAM HURDLES

Ideal for beginners. Stable and totally safe.

Width: 100 cm - Height: 40 cm - Thickness: 7 cm above and 25 cm below.

Ref	Product description
10340	Foam Hurdle



## TIPS

### What to do with... FOAM HURDLE MATS

Ref 23936, 23941, 23946

### START RUNNING OBSTACLE RACES using hurdle mats

For one class, offer three courses, A, B and C, so that each pupil can find the right difficulty level for them.

	Distances Start-1st obstacle			Distances between obstacles			Height of obstacles		
	A	B	C	A	B	C	A	B	C
Age 10-12	10 m	1.50 m	11m	6.60 m	7m	7.50 m	Yellow Hurdles 0.35m	Yellow Mats 0.35m	Blue Foam 0.50 m
Age 14-15	12m	12.60 m	13m	7.80 m	8.20 m	8.50 m	Blue Hurdles 0.50 m	Red Mats 0.65m	Red Foam 0.65m
Age 17-18	12.75m	13.20 m	13.50 m	8.20 m	8.50 m	8.75m	School Hurdles 0.76m	0.84m	0.91m



Pupils try the three courses to determine on which one they are capable of completing with 4 steps between each hurdle, and the fastest.



It is interesting to organize races between runners on different courses where the first hurdles of each course are aligned.



For the best athletes, the last Foam Mat obstacle is replaced by a school hurdle or mini-hurdle, to prepare the next step.



### ADJUSTABLE GPP FOAM HURDLES

Easy to set up and carry. Perfect for travelling athletes.

Ref	Product description
10339	Set of 5 hurdles



### CROSS-BRACED HURDLES

Lightweight and easy to set up. PVC hurdle boards 100 cm wide. Adjustable height 22 - 106 cm. Delivered with free storage bag.

Ref	Product description
10239	Set of 6 cross-braces hurdles with bag
10239001	Hurdle board for cross-braced hurdle - sold by unit

### BABY HURDLES

Ideal for athletics clubs and introductions to trackwork. Lacquered tubular steel with adjustable heights of 25 - 30 - 35 - 40 - 45 - 50 - 55 and 60 cm. Magnetic PVC hurdle board for enhanced safety.

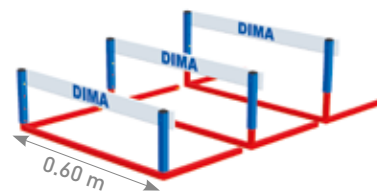

Ref	Product description
10235	Set of 3 baby hurdles
10238	Set of 6 baby hurdles
10235002	Set of 5 replacement PVC hurdle boards for baby hurdles



### DIMAKID HURDLES

Perfectly suitable for athletics, schools and track work. Lacquered steel construction, strong, easy to use and to stack. PVC hurdle boards placed on rubber supports. Delivered with a free storage bag.

Ref	Product description
10350	Set of 6 Dimakid Hurdles - 20 cm height with Storage Bag
10355	Set of 6 Dimakid Hurdles - 40 cm height with Storage Bag
10360	Mixed set of 6 Dimakid Hurdles (20 & 40 cm) with Storage Bag

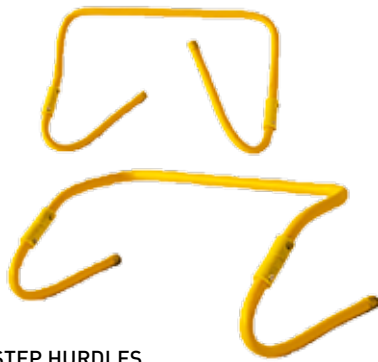

**FOLDABLE VARIABLE HEIGHT STEP HURDLES**

Lightweight and easy to transport due to its flat folding system. Ideal for footwork and trackwork. In tubular PVC. 15 or 30 cm height. Delivered with a free storage bag.

Ref	Product description
10234	Set of 6 Hurdles with Storage Bag

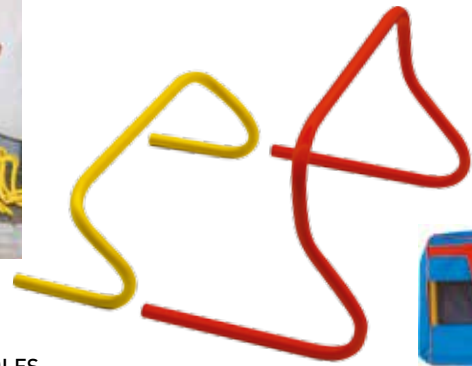

**STEP HURDLES**

Supplied with free storage bag. 45 cm width.

Ref	Product description
10232	Set of 6 - 15 cm height
10233	Set of 6 - 30 cm height
Transportation strap for step hurdles	
10237	Transportation strap



**FOLDABLE PVC TRAINING HURDLES**

Lightweight and easy to transport and install. Ideal for indoor training.

Ref	Product description
10323	Set of 10 - 20 cm height
10324	Set of 10 - 30 cm height
10325	Set of 10 - 40 cm height
10326	Set of 10 - 50 cm height

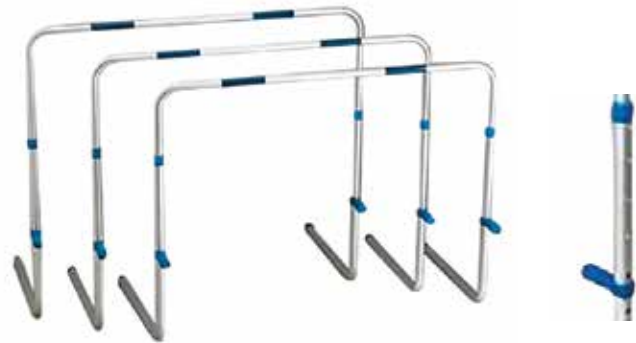

**ALUMINIUM AUTO RETURN HURDLES**

A hurdle that stands back up on its own, allowing for greater training frequency. Its all-aluminium design makes it an easily-transportable education aid, perfect for teaching schoolchildren indoors or outdoors. Fast adjustment of high using ball and spring system (40, 45, 50, 55 and 60 cm) Width: 1.00 m.

Ref	Product description
10210	Set of 3 aluminium auto-return hurdles



**PVC TRAINING HURDLES**

Perfect for beginners. Safe and easy to dismantle.

Ref	Product description
10331	Set of 3 - Adjustable from 40 to 60 cm
10337	Set of 3 - Adjustable from 55 to 95 cm
10332	Set of 6 - Adjustable from 40 to 60 cm



**GPP HURDLES**

Perfect for beginners. Adjustable height from 20 to 30 cm. PVC tube and joints. Can be fully dismantled. Lightweight. Width 60 cm.

Ref	Product description
10333	Set of 3 - height 20-30 cm
10334	Set of 3 - height 40-60 cm

# ATHLETICS



## INDOOR RUBBER SHOT

Specifically designed for throwing indoors or on a hard surface. Designed especially for intensive use.

Ref	Product description
12779	Indoor rubber shot 2 kg
12789	Indoor rubber shot 3 kg
12799	Indoor rubber shot 4 kg
12809	Indoor rubber shot 5 kg
12819	Indoor rubber shot 6 kg
12829	Indoor rubber shot 7.26 kg



## CAST IRON SHOT

Perfectly suitable for use in schools and clubs.

Ref	Product description
12601	Set of 3 - 2 kg
12611	Set of 3 - 3 kg
12621	Set of 3 - 4 kg
12631	Set of 3 - 5 kg
12641	Set of 3 - 6 kg
12651	Set of 3 - 7.26 kg



## STEEL SHOT

Officially approved. Balanced and weight-controlled.

Ref	Product description
12670	2 kg
12680	3 kg
12690	4 kg
12700	5 kg
12710	6 kg
12720	7.26 kg



## THROWING AREA

Easy to install and ideal for fun throwing practice. Throwing area in a 1,000 denier PVC fabric, in brilliant colours with metric measurements. Foam end edge to stop the equipment. Throwing circle with a circle mat secured to the throwing area using velcro strips. Dimensions : 8 x 5 m

Ref	Product description
11108	Throwing Area Dimensions: 8 x 5m



## SOFT RUBBER SHOT FOR SCHOOLS

Perfectly suited to children because the diameter is adapted to their hands for better acquisition of technique. Made from soft rubber.

Ref	Product description
12904	1 kg diam 100 mm
12905	1.5 kg diam 100 mm
12906	2 kg diam 110 mm
12907	3 kg diam 120 mm
12908	4 kg diam 125 mm
12909	5 kg diam 135 mm
12910	6 kg diam 140 mm
12911	7.26 kg diam 140 mm



## WEIGHTED BALLS

For shot put beginners, both indoors and outdoors. Moulded shape. The outer plastic cladding is non-slip and very resistant.

Ref	Product description
12840	200 g
12850	500 g
12860	1 kg
12870	1.5 kg
12880	2 kg
12890	3 kg



## IAAF CERTIFIED STEEL SHOT

Officially approved. For major competitions. Ball made of turned steel. Well balanced, weight controlled, refillable.

Ref	Product description
12742	4 kg diam 100 mm IAAF certified
12752	5 kg diam 114 mm IAAF certified
12754	6 kg diam 119 mm IAAF certified
12764	7.26 kg diam 125 mm IAAF certified



## SHOT RACK / CASE

Ref	Product description
12221	Mobile shot rack (10 - 15 shots)
12230	Shot case

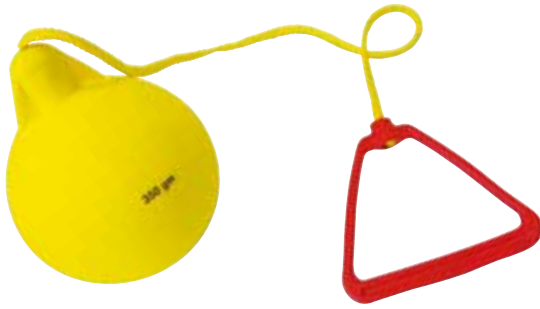

## RUBBER HAMMER

Perfectly suited for the youngest of beginners. This range does not present any dangers in its usage and allows the discovery of the best way to throw in a fun way.

Ref	Product description
13151	350 g
13150	1 kg
13152	1.5 kg
13153	2 kg



## HEAVY THROWING WEIGHT

Ideal for training. Weight adapted to your requirements.

Ref	Product description
13106	Heavy Throwing Weight

HEAVY THROWING WEIGHT IDEAL FOR TRAINING.  
WEIGHT ADAPTED TO YOUR REQUIREMENTS.



## HAMMER ACCESSORIES

Ref	Product description
13060	Replacement handle - training
13080	Replacement handle - competition
13091	Replacement cable - women 98 cm
13090	Replacement cable - men 100 cm
13095	Hammer case

## GLOVES

Ref	Product description
13048	Left Hand S
13049	Left Hand M
13050	Left Hand L
13056	Right Hand S
13055	Right Hand M
13051	Right Hand L



## OFFICIAL WEIGHTS FOR SHOT PUT AND HAMMER THROWING

CATEGORY	MALE	FEMALE
Under elevens	2 kg (1)	2 kg (1)
Children	3 kg (1)	2 kg (1)
Minors	4 kg	3 kg (1)
Cadets	5 kg	3 kg
Juniors	6 kg	4 kg
Seniors	7.26 kg	4 kg

(1) Total length of hammer may be shortened to 1 metre



## CAST IRON HAMMER

Ideal for schools, beginners and training. Solid moulded cast iron. Non-refillable. Steel cable mounted on a swivel. Resistant moulded aluminium handle.

Ref	Product description
12915	2 kg
12920	3 kg
12930	4 kg
12940	5 kg
12950	6 kg
12960	7.26 kg



## MEDICINE BALL WITH HANDLE

Perfectly suitable for children due to its ergonomic handle, for more accurate movement learning.

Ref	Product description
21354	1 kg - sold by unit
21364	2 kg - sold by unit
21366	3 kg - sold by unit
21374	4 kg - sold by unit



## MOBILE HAMMER RACK

Ref	Product description
12212	Mobile hammer rack

DIMA IS A MANUFACTURER: WE CAN MAKE THROWING DEVICES TO ORDER ACCORDING TO DESIRED WEIGHT (SUITED TO TRAINING CONDITIONS)

# ATHLETICS



## INTERCLUB WOODEN DISCUS

Officially approved. Highly technical. Laminated sideplate. Steel rim. Diameter 16 cm.

Ref	Product description
12300	600 g
12301	800 g
12302	1 kg
12303	1.25 kg
12304	1.5 kg
12305	1.75 kg
12306	2 kg



## PLASTIC CHALLENGER DISCUS

Steel rim and sideplate in very resistant plastic. Blue.

Ref	Product description
12000	600 g
12020	800 g
12030	1 kg
12040	1.25 kg
12050	1.5 kg
12060	1.75 kg
12080	2 kg



## IAAF DISCUS

IAAF approved & certified\*. Olympic Games medal winner. Discus with 75% of its weight concentrated in its steel rim, for a great spinning speed. Very resistant ABS sideplate. Red.

Ref	Product description
12480	600 g
12481	800 g
12520	1 kg I.A.A.F
12251	1.25 kg
12530	1.5 kg I.A.A.F
12540	1.75 kg I.A.A.F
12550	2 kg I.A.A.F



## DISCUS BAG

Case made of 1000 denier Tergal fabric. Very solid. Easy transportation of equipment.

Ref	Product description
12215	Discus bag



## MOBILE DISCUS RACK

Major competition display rack for stacking various discus. Very mobile, mounted on two wide rubber wheels. Easily moved. Capacity : 28 Discuses

Ref	Product description
12213	Mobile Discus Rack



## THROWING DISTANCE FIELD MARKERS

Set of 12 field markers

Ref	Product description
10440	Short distance
10460	Long distance



## METRIC TAPE

In unwoven fabric. Very light and easy to position. 17 cm wide. Markings every 20 cm.

Ref	Product description
10390	20 m. Tape
10395	50 m. Tape



## FIBRE GLASS MEASURING TAPE

Flexible and tear-resistant

Ref	Product description
11500	10 m.
11510	20 m.
11520	30 m.
11522	50 m with Handle
11525	100 m with Handle



## STEEL MEASURING TAPE

Ref	Product description
11430	10 m.
11440	20 m.
11450	30 m.
11470	30 m with Handle
11480	50 m with Handle
11490	100 m with Handle



## VINYL TAPE

Usable indoors and outdoors to mark play and work areas. Can be cut to make stride indicators. Composition: In soft PVC. 4 cm. width. Various colours.

Ref	Product description
10373	Vinyl Tape 10 m
10374	Vinyl Tape 20 m

## MULTI-USE CART

Designed for easy storage of your throwing devices, this cart is equipped with three levels of sorting trays and a special javelin rack. Made from lacquered steel, fitted with 2 rubber wheels. Dimensions: 100 cm high, 61 cm wide, 58 cm long (80 with handles)

Ref	Product description
10107	Multi-use cart



## DISTANCE MEASURING WHEEL

Ref	Product description
11640	Measuring wheel with carrying bag

OFFICIAL WEIGHTS FOR DISCUS THROWING

CATEGORY	MALE	FEMALE
Under elevens	800 g	600 g
Children	1 kg	600 g
Minors	1.25 kg	800 g
Cadets	1.5 kg	1 kg
Juniors	1.75 kg	1 kg
Senior 1	2 kg	1 kg



PVC HANDLED STARTER DISCUS

Perfectly suited to learning the right technique. 3 grips possible. Made from PVC.

Ref	Product description
12386	400 g
12387	600 g
12388	800 g



SOFT DISCUS

Very soft rubber. Brightly coloured. This range offers total safety for beginners, with no danger to even the smallest children.

Ref	Product description
12384	Set of 3 discs 200 g
12383	Set of 3 discs 300 g
12385	Set of 3 -discs 500 g



RUBBER DISCUS

Designed for use by schools. Unbreakable, safe, Colour-coded by weight and category. Ideal for all types of surface.

Ref	Product description
12340	600 g
12341	800 g
12350	1 kg
12351	1.25 kg
12360	1.5 kg
12370	1.75 kg
12380	2 kg



THROWING RINGS

Ref	Product description
75110	Set of 6 rubber rings
75121	Set of 3 throwing rings 400 g
75131	Set of 3 throwing rings 600 g



TIPS  
DIMA  
What to do with...  
A DISCUS AND A JAVELIN

BEFORE BEING ABLE TO THROW A LONG WAY  
PRACTICE YOUR MANUAL DEXTERITY  
WITH A DISCUS AND A JAVELIN



With a discus

Standing up, the thrower swings his arm forwards and backwards once, then, on the next forward movement, bends his knees so as to release the discus along the ground, with the index finger being the last in contact with the discus. The technique is identical for left and right-handers... and there's no need to confuse them with clockwise or anticlockwise rotation! Measure the performance by marking the zone in which the discus stops.

With a javelin

3 targets made from hoops clipped to poles, with diameters of 0.70m, 0.50 m and 0.35m. The aim is to throw the javelin through the hoops without touching them.

Or

With run-ups of 5m, 7.50m and 10 m, throw a javelin between 2 poles positioned 0.50m apart.

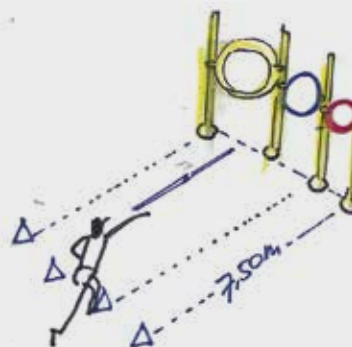

## TIPS

### What to do with... A JAVELIN



### If there is not enough space to throw far, THROW HARD AND ACCURATELY

Stab the javelin into the long jump pit in 3 target hoops 5m, 7.50m and 10m away.



### THROWING SPORTS REQUIRE STRICT COMPLIANCE WITH SAFETY RULES AND INSTRUCTIONS



Making the javelin stick in the sand requires strength but also trajectory angle.

Awards points according to whether the target is hit and whether the javelin sticks in the sand.

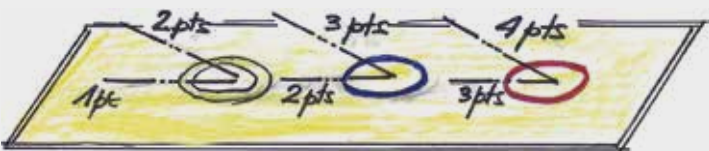

### TARPAULIN TARGET FOR THROWING EVENT

LANDING AREA - 300 x 100 cm

With colour coded zones for easier identification

Ref	Product description
70097	Throwing event landing area



### VERTICAL TARPALIN TARGET FOR THROWING - 130 x 130 cm

With coloured circles and eyelets, can be hung vertically.

Ref	Product description
70098	Tarpaulin target

### SET OF TARGET HOOPS

Kit offering a host of combinations to develop motor skills and throwing proficiency. Comprising 3 hoops of 75 cm diameter, 6 base blocks, 6 x 1.80 m poles and 6 fixing clips.

Ref	Product description
10190	Set of 3 target hoops



### TARGET AREA

Made with anti-spike fabric with different colours with velcro feet for attaching to high jump uprights or other equipment. Target area adjustable for three levels (64 cm, 42 cm or 23 cm diameter), using velcro.

Ref	Product description
70099	Target Area

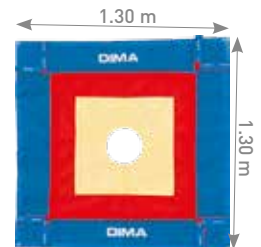

### OFFICIAL WEIGHTS FOR JAVELIN THROWING

AGE (INDICATIVE)	MALE	FEMALE
Under elevens	400 g	300 g
Children	500 g	400 g
Minors	600 g	500 g
Cadets	700 g	500 g
Juniors	800 g	600 g
Seniors	800 g	600 g





## TURBOJAV

Perfect for beginners. Made from tough plastic.

Ref	Product description
11720	Turbojav – Sold by unit



## VORTEX

Ref	Product description
11726	Set of 3 Vortex Javelins
11724	Set of 6 Vortex Javelins



## FOAM JAVELIN

Ref	Product description
11723	Foam javelins- 90 cm / 50 g - Sold by unit



## COMET BALLS

Ball with ribbon to follow trajectory. Used with a thrower device, it is a fun way to acquire the tricky technique of throwing.

Ref	Product description
11715	Set of 6 throwers and 6 comet balls
11716	Set of 6 comet balls
11717	Set of 6 throwers



## JAVELIN BALLS

Ref	Product description
11730	200 g
11731	400 g
11732	600 g
11733	800 g

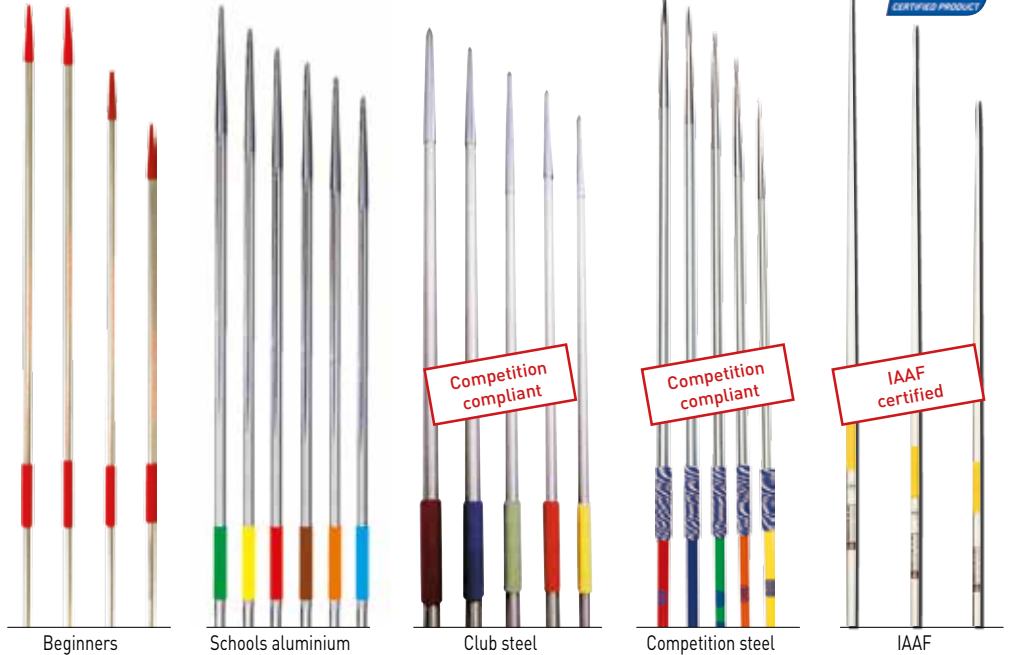

Our javelins' tube and handle colours are not contractual and may vary.

## BEGINNERS JAVELIN PLASTIC TIP

Very safe javelin, with a plastic tip. Ideal for school beginners.

Ref	Product description
14152	Set of 3-300 g
14154	Set of 3-400 g
14155	Set of 3-500 g
14156	Set of 3-600 g

## STEEL COMPETITION JAVELIN

**Officially approved.** Well-made, rigid, Rigid, solid, string handle, zinc-plated steel tip, shiny, and painted in different colours for each weight.

Optimum centre of gravity.

Ref	Product description
11740	400 g
11750	500 g
11760	600 g
11770	700 g
11780	800 g

## IAAF JAVELINS

Streamlined and balanced, coloured string handle for better identification of weights, steel point.

Ref	Product description
11761	600 g IAAF certified
11771	700 g IAAF certified
11781	800 g IAAF certified

## JAVELIN DISPLAY RACK

Display case containing a great number of javelins and able to be used for storage. In steel with epoxy paint.

Ref	Product description
12240	Wheeled javelin rack
12010	4-javelin carrying case
12241	Javelin carrying tube

## ALUMINIUM SCHOOLS JAVELIN

Well weighted. Steel tip. String handles in different colours according to weight.

Ref	Product description
11675	Set of 3-300 g
11691	Set of 3-400 g
11651	Set of 3-500 g
11661	Set of 3-600 g
11671	Set of 3-700 g
11681	Set of 3-800 g

## STEEL CLUB JAVELIN

**Officially approved.** Well-made, rigid, solid, string handle, one epoxy colour for each weight.

Ref	Product description
11851	Set of 3-400 g
11852	Set of 3-500 g
11853	Set of 3-600 g
11854	Set of 3-700 g
11855	Set of 3-800 g



Ref 12010

Ref 12240

Ref 12241

# ATHLETICS



## HIGH JUMP FIBRE GLASS CROSSBARS

Made from coiled fibre glass, solid; lightweight and fitted with semi-circular ends.

Ref	Product description
14400	4m regulation compliant (high jump)
14401	4m IAAF certified (high jump)



Ref 10580



Ref 10570



Ref 10560

## SAFETY CROSSBARS

A totally safe alternative to a crossbar

Ref	Product description
10570	Foam elastic crossbar 5 m (for high jump and pole vault)
10580	Elastic tape crossbar 3 – 5 m (for high jump and pole vault)
10560	Elastic roll – diam 6 mm



## HEIGHT GAUGE

Ref	Product description
11541	Aluminium school high jump height gauge, marked, 2 m
11560	Aluminium high jump height gauge, graduated, 2.50 m with sliding marker
11581	Telescopic high jump height gauge from 0.85 to 3.00 m



Ref 14150



Ref 14320



Ref 14310

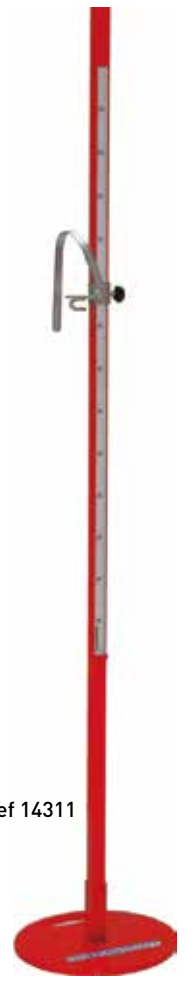

Ref 14311

## SCHOOL HIGH JUMP STANDARDS

Basic model. Good value for money for school environment. Fitted with rests and hooks on which to place a crossbar or attach an elastic tape. Graduations from 50 cm to 200 cm, easy to read. T-shaped base with rubber pads.

Ref	Product description
14150	School high jump standards (pair)

## MULTI-POSITION HIGH JUMP STANDARDS

Ideal for schools or training. Allows the crossbar or elastic tape to be quickly positioned at various heights from 0.60 m to 2.20 m, using 14 graduated crossbar supports placed every 5cm. Heavy base to avoid any risk of falling over.

Ref	Product description
14320	Multi-position high jump standards

## CLUB HIGH JUMP STANDARDS WITH DEFLECTOR-FITTED CROSSBAR RESTS

Same design as ref. 14310 but fitted with deflectors to prevent crossbar falling vertically and injuring athlete on landing.

Ref	Product description
14311	Club high jump standards with deflectors (pair)



## HIGH JUMP STANDARD CART

Ref	Product description
14312	High Jump Standard Cart

## CLUB HIGH JUMP STANDARDS

Galvanised aluminium crossbar rests with hook for elastic tape. Graduations from 0.60 m to 2.20 m. Heavy base.

Ref	Product description
14310	Club high jump standards (pair)

## FOLDAWAY WHEELED HIGH JUMP LANDING SYSTEM

A landing system with DIMA's quality and expertise. This landing system is placed on a foldaway platform. It offers ultimate safety thanks to a spring system allowing for effortless manipulation. Folds reinforced by polyamide band. Easy to move with 2 fixed wheels and 2 pivoting and self-blocking wheels. Can be stored in a small space.



Leather grain surface



Reinforced fold



Handles



Ref	Product description
16190	400 x 200 x 50 cm (folded 210 x 200 x 100 cm)
16200	400 x 200 x 60 cm (folded 210 x 200 x 120 cm)
16220	450 x 250 x 60 cm (folded 235 x 250 x 120 cm)

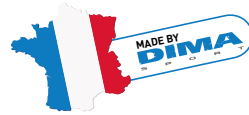

## COVER FOR FOLDAWAY LANDING SYSTEM

Ref	Product description
16215	400 x 200 x 40 cm
16210	400 x 200 x 50 cm
16225	450 x 250 x 50 cm
15861	Cover sold by sqm

## WEATHER COVER FOR FOLDED LANDING SYSTEM

Ref	Product description
16190030	210 x 120 x 200 cm (for ref. 16190)
16200030	210 x 140 x 200 cm (for ref. 16200)
15862	Cover sold by sqm



COVER FOR 3-SECTION LANDING SYSTEM ON REQUEST

## 3-SECTION FOLDAWAY LANDING SYSTEM

Ref	Product description
16140	400 x 200 x 40 cm (folded 200 x 200 x 80 cm)
16150	400 x 200 x 50 cm (folded 200 x 200 x 100 cm)
16170	450 x 250 x 50 cm (folded 225 x 250 x 100 cm)

## TRANSPORT CART

Ref	Product description
16155	200 x 200 x 10 cm (4 wheels)

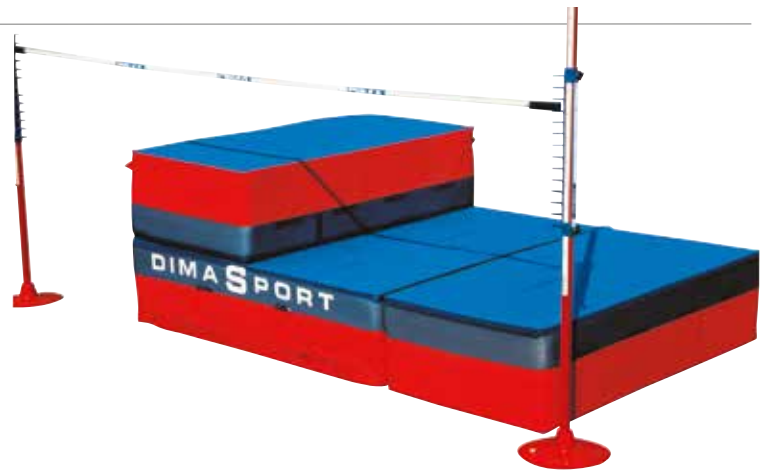
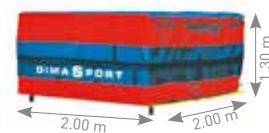

## 3-SECTION FOLDAWAY LANDING SYSTEM ON CENTRAL PLATFORM

The centre section rests on a platform fitted with pivoting and self-blocking casters.

Ref	Product description
16500	400 x 200 x 65 cm (folded 200 x 200 x 130 cm)
16510	450 x 250 x 65 cm (folded 225 x 250 x 130 cm)
16520	500 x 300 x 75 cm (folded 250 x 300 x 150 cm)

## COVER FOR 3-SECTION FOLDAWAY LANDING SYSTEM ON PLATFORM (MATTRESS FOLDED)

Ref	Product description
16501	200 x 200 x 130 cm
16511	225 x 250 x 130 cm
16521	250 x 300 x 150 cm



# ATHLETICS

## Composition

- High quality polyurethane foam covered with 1000 denier flame-retardant certified Tergal fabric,
- Leather grain surface and non-slip underside and an air-escape grid all around the mattress for a softer landing. Zip fastening on 3 sides.
- Non-tear handles with 8 stitch points **into the mattress** allowing for easier transportation.

**FOLDAWAY MATTRESSES**

Our foldaway safety mattresses are inseparable in order to take up less space, and be easily transportable and storable (can stand up against a wall). Non-tear assembly of mattress components using seatbelt-type straps.

**DIMA EXTRAS**

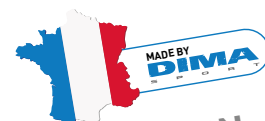

**MADE IN OUR FACTORY IN PARIS REGION**



These models have been specifically designed for intensive use in a collective environment. Compliant with safety standard NF EN 12503

**5 year guarantee**



## ONE PIECE HIGH JUMP LANDING SYSTEM

Ref	Product description
15950	300 x 200 x 40 cm
15965	300 x 200 x 50 cm
15960	400 x 200 x 40 cm
15970	400 x 200 x 50 cm
15980	450 x 250 x 50 cm
15990	500 x 250 x 50 cm
15995	500 x 300 x 50 cm

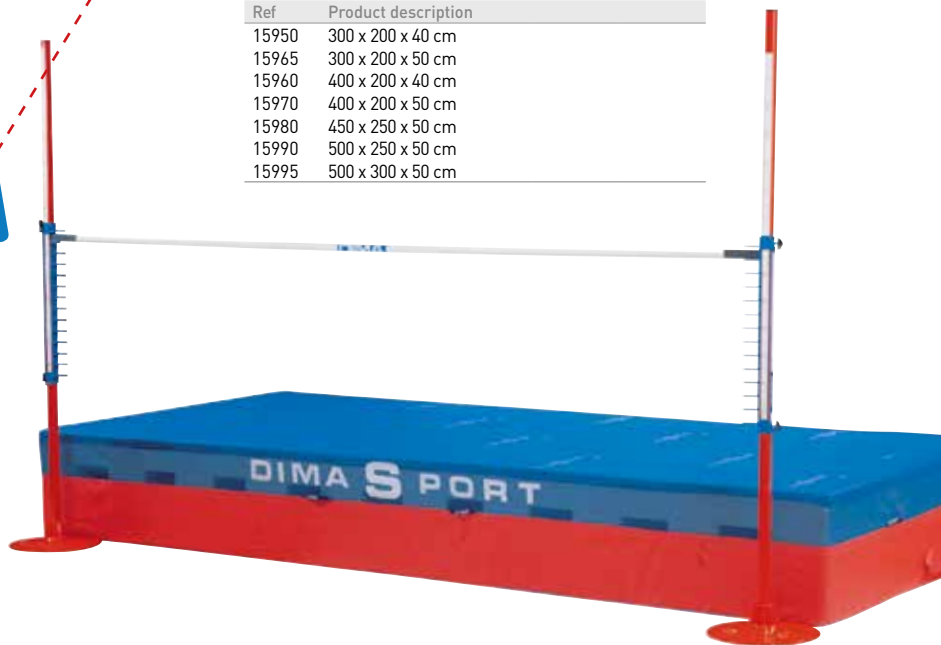

**MATTRESS LOCKING COVER ON REQUEST**

## MODULAR ONE-PIECE LANDING SYSTEM

Elements can be joined together using Velcro straps

Ref	Product description
15900	200 x 100 x 40 cm
15905	200 x 100 x 50 cm
15910	250 x 120 x 50 cm
15920	250 x 150 x 50 cm



## REPLACEMENT COVER

Ref	Product description
16000	200 x 100 x 40 cm
16005	200 x 100 x 50 cm
16010	250 x 120 x 50 cm
16020	250 x 150 x 50 cm
16030	300 x 200 x 40 cm
16045	300 x 200 x 50 cm
16040	400 x 200 x 40 cm
16050	400 x 200 x 50 cm
16060	450 x 250 x 50 cm
16070	500 x 250 x 50 cm
16080	500 x 300 x 50 cm
15861	Cover sold by sqm

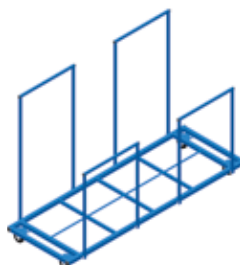

Ref 22353



Ref 17110

## TRANSPORTATION CART FOR ONE-PIECE MATTRESS

Ref	Product description
17110	Dim. 274 x 60 x 25 cm
22353	Dim. 200 x 75 x 1360 cm

## AIRFOAM STRUCTURE HIGH JUMP LANDING SYSTEM

A good compromise for minor competitions, school use and training. Optimal comfort and safe landing for athletes' safety.

**Certified NF EN 12503.**

- Cross-braced airfoam blocks, 24kg density multi-support
- Unique cover with spike-proof surface and air release grid around the perimeter for a softer landing
- Surround and base made from 1000 denier heavy tergal.
- Non-tear polyamide handles with 8-point stitching, placed in the depth of the mattress to allow easy handling.

**Blocks interchangeable to extend lifespan**



Cross-braced airfoam blocks, 24kg density multi-support, for controlled and comfortable landing.

## AIRFOAM SCHOOL LANDING SYSTEM

Ref	Product description
15760	400 x 200 x 50 cm

## PE AIRFOAM LANDING SYSTEM

Ref	Product description
15840	450 x 250 x 50 cm

## CLUB AIRFOAM LANDING SYSTEM

Ref	Product description
19090	500 x 300 x 50 cm

## COMPETITION AIRFOAM LANDING SYSTEM

Ref	Product description
19083	500 x 300 x 70 cm (Compliant with French and IAAF level 1 standards)



## WEATHER COVER

Essential for protecting landing systems outdoors.

1000 denier tergal canvas. Buckle and strap system stitched into cover in corners to tighten cover over mattress and prevent lifting by wind.

Ref	Product description
16981	300 x 200 x 40 cm
16980	300 x 200 x 50 cm
16982	400 x 200 x 40 cm
15761	400 x 200 x 50 cm
15841	450 x 250 x 50 cm
16983	500 x 250 x 50 cm
16615	500 x 300 x 50 cm
19031	500 x 300 x 70 cm

## PLATFORM

Galvanised metallic platform elevated 10cm on wide feet, equipped with side bars to maintain mattress blocks. Supplied in separate elements with fixing jaws.

Ref	Product description
15741	Platform 300 x 200 x 10 cm
15765	Platform 400 x 200 x 10 cm
15845	Platform 450 x 250 x 10 cm
15812	Platform 500 x 250 x 10 cm
15847	Platform 500 x 300 x 10 cm

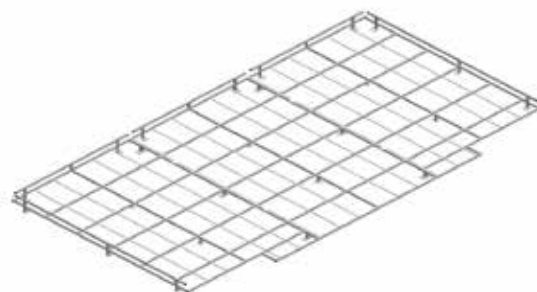

1-element, 1-door high jump shed



## SHEDS

Description	Mattress size	Shed size	FIXED WHEELS	SWIVELLING WHEELS
			Référence	Référence
PE high jump shed	4.50 x 2.50 m	5.00 x 3.00 x 1 m	15500F	15500
Basic high jump shed	5.00 x 2.50 m	5.50 x 3.00 x 1 m	15501F	15501
Club high jump shed	5.00 x 3.00 m	5.50 x 3.40 x 1 m	15611F	15611

Interchangeable module system using buckles and straps allows for more versatile use of the landing system.

- Cross-braced airfoam blocks, 24kg density multi-support
- Encased individually and attached together with buckles and straps, covered with 7cm thick spike-proof top pad ensuring a uniform landing area.
- Surround and base of covers made from 1000 denier heavy tergal.
- Each block equipped with non-tear handles to allow easy handling.
- Blocks interchangeable to extend lifespan.



**MADE IN OUR FACTORY IN PARIS REGION**



Ideal for schools and beginners

Items can be arranged in high jump or pole vault configuration or used independently.



### BASIC POLE VAULT LANDING SYSTEM

Ref	Product description
17250	500 x 425 x 67 / 40 cm
17251	Weather cover
14045	Platform
15510F	Basic pole vault shed



### BASIC HIGH JUMP LANDING SYSTEM

Ref	Product description
17200	500 x 250 x 67 cm
17201	Weather cover
15812	Platform
15501F	Basic high jump shed

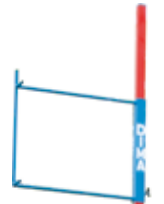

### BASIC ITEMS

Ref	Product description
17149	Basic module 250 x 167 x 60 cm - (sold by unit)
17220	Spike-proof top pad 250 x 500 x 7 cm - (sold by unit)
17230	2 Basic front extensions 200 x 175 x 60 / 40 cm

### BASIC POLE VAULT UPRIGHTS

Ideal for beginners. Bar height adjustable from 1.00 to 4.80m. Heavy and stable bases on wheels for transportation. The moving of the upright is performed using rails.

Ref	Product description
14260	Complete Basic Uprights (per pair)

## TIPS

### What to do with... A POLE

#### FOAM POLE SUPPORT

Ideal for beginners and early learning, this small weighted foam module allows the pole to be placed in a steel tube to teach the pupils how to manipulate the pole.

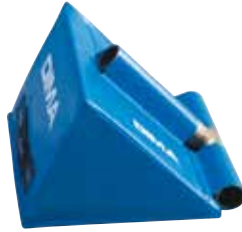

Ref	Product description
11104	Foam Pole Support

#### FREE STANDING VAULT BOX

Ideal for beginners. Made from galvanised steel. Can be freely placed in the ground without fixings. Fits into the niche made by the Basic front extensions. Supplied with foam protection. Easy to "plant" pole and looks like a real vault box.



Ref	Product description
11105	Dim. 70 x 52 x 27 cm

#### MOVABLE TRAINING VAULT BOX

Vault box. Requires weighing down. For "planting" exercises.



Ref	Product description
11102	Movable Training Vault Box

#### FOAM VAULT BOX

Used to "block" the pole for beginners



Ref	Product description
11106	Foam Vault Box

#### POLE VAULT FIBRE GLASS CROSSBARS

Made from coiled fibre glass, solid; lightweight and fitted with semi-circular ends.



Ref	Product description
14410	4.50m regulation compliant
14411	4.50m IAAF certified



Ref 10580



Ref 10560

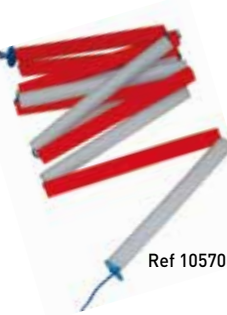

Ref 10570

#### SAFETY CROSSBARS

Ref	Product description
10570	Foam elastic crossbar 5m
10580	Elastic tape crossbar 3 - 5m
10560	25m elastic roll - diam 6mm

#### HEIGHT GAUGE

Ref	Product description
11541	Aluminium height gauge, graduated, 2m
11581	Telescopic high jump height gauge from 0.85 to 3.00m
11582	Telescopic gauge from 1.80 to 8m



#### ENJOYING POLE VAULTING

IS POSSIBLE, EVEN FOR THE YOUNGEST CHILDREN IN THE GYM OR THE SAND PIT.

#### 2 MISTAKES TO AVOID:



**RIGHT HAND AT TOP** means lift off with left leg and body to the right of the pole. Left hand at top: right leg lifts off and body goes to the left of the pole.



The trainer should not pull on the pole and should merely attempt to keep it vertical. It is the pupil's job to push their pole. This is why it is good idea to place cones in the sand. In the gym, use DIMA's vault boxes and supports.

## LONG JUMPING WITH A POLE

# TIPS

## What to do with... A POLE



### IN THE SAND PIT WITH A LEVER

POLE LENGTH FROM END TO BE PLANTED IN THE HOOP TO THE UPPER HAND

WELL IDENTIFIED AND FOLLOWED

This fun exercise is a great way of teaching technique, as the jumper always has to stay behind their pole. This is one of the basics of pole vaulting, even at the highest level!

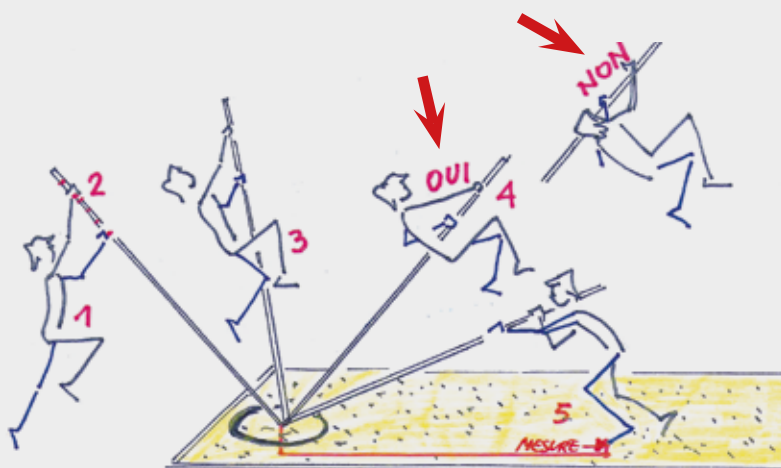

- 1 Knee lift with leg opposite the upper "lead" hand.
- 2 Lever length markers (coloured tape every 20cm for example)
- 3 Bring legs together at knees
- 4 Always push down on pole so as to never pass in front of it!
- 5 Balanced descent – pole on shoulder facing back towards run-up... and then measure the distance.



### BEGINNERS FIBRE GLASS POLE 200CM

Designed for school beginners, fibre glass pole

Ref	Product description
10080	Beginners pole



### DIMA LANCET BEGINNERS FIBRE GLASS POLE

Fibre glass, light, perfectly suitable for beginners due to its flexibility.

Ref	Length / Weight	Ref	Length / Weight
27024	270 cm / 24 kg	18000	310 cm / 25 kg
27027	270 cm / 27 kg	18200	310 cm / 27 kg
27030	270 cm / 30 kg	18010	310 cm / 30 kg
27033	270 cm / 33 kg	18210	310 cm / 33 kg
27035	270 cm / 35 kg	18020	310 cm / 35 kg
27037	270 cm / 37 kg	18220	310 cm / 37 kg
27041	270 cm / 41 kg	18230	310 cm / 40 kg
27044	270 cm / 44 kg	18240	310 cm / 43 kg
		18250	310 cm / 45 kg

14950001 Tip for Lancet beginners fibre glass pole

### PACER DIMAGIC STICK POLE

Lower flexion point, therefore easier. Thinner profile for easier handling.



Ref	Length / Weight	Tip No
<b>DIMAGIC STICK 335 SERIES</b>		
19512	335 cm / 36 kg (80 lbs)	21
19513	335 cm / 41 kg (90 lbs)	21
19514	335 cm / 45 kg (100 lbs)	21
19515	335 cm / 50 kg (110 lbs)	21
<b>DIMAGIC STICK 360 SERIES</b>		
19521	360 cm / 41 kg (90 lbs)	21
19522	360 cm / 45 kg (100 lbs)	21
19523	360 cm / 50 kg (110 lbs)	21
19524	360 cm / 54 kg (120 lbs)	21
19525	360 cm / 59 kg (130 lbs)	21
<b>DIMAGIC STICK 400 SERIES</b>		
19532	400 cm / 50 kg (110 lbs)	21
19533	400 cm / 52 kg (115 lbs)	21
19534	400 cm / 54 kg (120 lbs)	21
19535	400 cm / 57 kg (125 lbs)	21
19536	400 cm / 59 kg (130 lbs)	21



### PACER DIMAGIC STICK CARBON POLE

Carbon brings lightness, thrust and allows for a thin profile.

Ref	Length / Weight	Tip No
<b>PACER CARBONE 415 SERIES</b>		
71501	415 cm / 57 kg (125 lbs)	16
71502	415 cm / 59 kg (130 lbs)	16
71503	415 cm / 61 kg (135 lbs)	16
71504	415 cm / 63 kg (140 lbs)	16
<b>PACER CARBONE 425 SERIES</b>		
71511	425 cm / 59 kg (130 lbs)	16
71512	425 cm / 61 kg (135 lbs)	16
71513	425 cm / 63 kg (140 lbs)	16
71514	425 cm / 66 kg (145 lbs)	16
<b>PACER CARBONE 440 SERIES</b>		
71521	440 cm / 61 kg (135 lbs)	13
71522	440 cm / 63 kg (140 lbs)	13
71523	440 cm / 66 kg (145 lbs)	13
71524	440 cm / 68 kg (150 lbs)	13



## PACER FX POLE

A new generation fibre application brings this pole generation unparalleled lightness and dynamism.



Ref	Length / Weight	Tip No
<b>FIBRE 350 SERIES</b>		
15025	350 cm / 45 kg (100 lbs)	21
15026	350 cm / 54 kg (120 lbs)	21
15027	350 cm / 59 kg (130 lbs)	16
<b>FIBRE 375 SERIES</b>		
15002	375 cm / 45 kg (100 lbs)	21
15003	375 cm / 54 kg (120 lbs)	18
15004	375 cm / 63 kg (140 lbs)	18
<b>FIBRE 400 SERIES</b>		
15030	400 cm / 50 kg (110 lbs)	18
15040	400 cm / 54 kg (120 lbs)	18
15050	400 cm / 59 kg (130 lbs)	18
15060	400 cm / 63 kg (140 lbs)	18
15070	400 cm / 68 kg (150 lbs)	18
<b>FIBRE 425 SERIES</b>		
15090	425 cm / 57 kg (125 lbs)	16
15100	425 cm / 59 kg (130 lbs)	16
15110	425 cm / 61 kg (135 lbs)	13
15120	425 cm / 63 kg (140 lbs)	13
15130	425 cm / 66 kg (145 lbs)	13
15140	425 cm / 68 kg (150 lbs)	13
15150	425 cm / 70 kg (155 lbs)	13
15160	425 cm / 73 kg (160 lbs)	13
15161	425 cm / 75 kg (165 lbs)	13
15162	425 cm / 77 kg (170 lbs)	10
15163	425 cm / 80 kg (175 lbs)	10
<b>FIBRE 440 SERIES</b>		
18334	440 cm / 59 kg (130 lbs)	13
18336	440 cm / 61 kg (135 lbs)	13
18338	440 cm / 63 kg (140 lbs)	10
18340	440 cm / 66 kg (145 lbs)	10
18342	440 cm / 68 kg (150 lbs)	10
18344	440 cm / 70 kg (155 lbs)	10
18346	440 cm / 73 kg (160 lbs)	10
<b>FIBRE 460 SERIES</b>		
15180	460 cm / 63 kg (140 lbs)	10
15190	460 cm / 66 kg (145 lbs)	10
15200	460 cm / 68 kg (150 lbs)	10
15210	460 cm / 70 kg (155 lbs)	10
15220	460 cm / 73 kg (160 lbs)	7
15230	460 cm / 75 kg (165 lbs)	7
15240	460 cm / 77 kg (170 lbs)	0
15250	460 cm / 80 kg (175 lbs)	7
15251	460 cm / 82 kg (180 lbs)	5
15253	460 cm / 84 kg (185 lbs)	5

## PACER FX CARBON POLE

The advantages of a new fibre application combined with carbon, resulting in a considerably lighter pole.



Ref	Length / Weight	Tip No
<b>CARBONE 460 SERIES</b>		
71600	460 cm / 63 kg (140 lbs)	10
71610	460 cm / 66 kg (145 lbs)	10
71620	460 cm / 68 kg (150 lbs)	10
71630	460 cm / 70 kg (155 lbs)	10
71640	460 cm / 73 kg (160 lbs)	10
71650	460 cm / 75 kg (165 lbs)	10
71660	460 cm / 77 kg (170 lbs)	10
71670	460 cm / 80 kg (175 lbs)	10
71680	460 cm / 82 kg (180 lbs)	10
71690	460 cm / 84 kg (185 lbs)	10
<b>CARBONE 490 SERIES</b>		
70310	490 cm / 73 kg (160 lbs)	10
70340	490 cm / 75 kg (165 lbs)	10
70370	490 cm / 77 kg (170 lbs)	10
70400	490 cm / 80 kg (175 lbs)	10
70430	490 cm / 82 kg (180 lbs)	7
70450	490 cm / 84 kg (185 lbs)	7
70480	490 cm / 86 kg (190 lbs)	5
<b>CARBONE 500 SERIES</b>		
71010	500 cm / 77 kg (170 lbs)	7
71020	500 cm / 80 kg (175 lbs)	7
71070	500 cm / 82 kg (180 lbs)	7
71120	500 cm / 84 kg (185 lbs)	7
71170	500 cm / 86 kg (190 lbs)	5
71171	500 cm / 88 kg (195 lbs)	5
71172	500 cm / 91 kg (200 lbs)	4
71173	500 cm / 93 kg (205 lbs)	4
71174	500 cm / 95 kg (210 lbs)	2

## PACER POLE TIPS

Ref	Tip No	Ref	Tip No
14932	2	14940	10
14934	4	14943	13
14935	5	14946	16
14937	7	14948	18
		19600	21



## CAR RACK

Ref	Product description
15570	Pole car rack (sold in pairs)

## POLE MANUFACTURE

### WRAPPING FIBRE GLASS SHEETS



### INDIVIDUAL CURING OF POLES IN SPECIFIC OVENS ACCORDING TO DIAMETER



### POLE STRESS AND FLEX TESTS



## POLE TRANSPORTATION BAGS

Ref	Length	Ref	Length
15458	3.10 / 3.35 m	15480	4.80 / 5.00 m
15459	3.50 / 3.75 m	15455	Customisation
15460	4.00 / 4.25 m	15490	Padlock security
15470	4.40 / 4.60 m	15491	Rigid sheath, sold per metre

# ATHLETICS



5 year guarantee

## POLE VAULT PLUS ATHLETICS PACK

Comprising:

2 school beginner poles, 1 school DIMA Lancelt 310cm/30kg pole, 2 foam vault boxes, 1 foam elastic crossbar, 12 rubber 18cm high jump cones, 4 foam hoops diam. 50cm, 20 stride indicators.

70130



## POLE VAULT ATHLETICS PACK

Comprising:

3 beginner poles, 1 set of 3 vault mats, 1 foam elastic crossbar, 1 set of 20 stride indicators.

70140

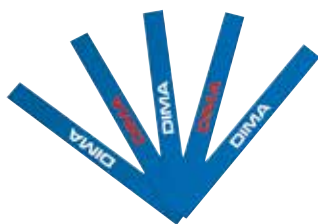

Ref 10372



Ref 11107



Ref 10570



Ref 10080

## DIMA BAG

With a reputation for solidity and great resistance, washable and waterproof, your DIMA bag will follow you everywhere.

Dimensions : Small DIMA bag 50 x 37 x 30 cm

Large DIMA bag 70 x 46 x 40 cm

### CUSTOMISED BAG

Create your logo, we will silk-screen print it. Send your design to DIMA with your order form, by fax, post, or e-mail.

Ref	Product description
10832	Large Blue Customised Bag
10833	Large Red Customised Bag
10834	Small Blue Customised Bag
10791	Small Red Customised Bag

**NOTE: MINIMUM ORDER OF 30 BAGS.**

## STANDARD DIMA BAG

Ref	Product description
10801	Large Blue Bag
10802	Large Red Bag
10790	Small Blue Bag
10789	Small Red Bag

Ref 10801

Ref 10789



CUSTOMISED BAGS

## SHEDS

Essential for the effective protection of your equipment against the elements and vandalism and to guarantee its durability.

- **High-resistance hot-dipped galvanised steel chassis.**
- Galvanised and painted sheet metal, compliant with building norms P34301 and certified fire resistant (French standard M0).
- **Pre-formed ribbed roof** for greater resistance and better water runoff.
- Waterproof aluminium rivets and washers.
- Edging fitted with rubber buffers. Watertight rubber joints and seals.
- Door struts.
- Corners protected by folded and galvanised sheet metal edging.
- **Transportation handles.** Single-lock padlock security. Supplied in preassembled elements with assembly instructions.



High jump shed with 1 element and 1 door.

CONSULT OUR FULL RANGE OF SHEDS IN OUR ATHLETICS CATALOGUE OR ON OUR WEB SITE [www.dimasport.fr](http://www.dimasport.fr) FOR FURTHER INFORMATION PLEASE FEEL FREE TO CONTACT US AT [info@dimasport.fr](mailto:info@dimasport.fr) on +33 1 64 40 05 70

## SHEDS

Product description	Mattress size	Shed size	FIXED WHEELS	SWIVELLING WHEELS
			Reference	Reference
PE high jump shed	4.50 x 2.50 m	5.00 x 3.00 x 1.20 m	15500F	15500
Basic high jump shed	5.00 x 2.50 m	5.50 x 3.00 x 1.20 m	15501F	15501
Club high jump shed	5.00 x 3.00 m	5.50 x 3.40 x 1.20 m	15611F	15611
Basic pole vault shed	5.00 x 4.25 m	5.40 x 4.60 x 1.20 m	15510F	15510



## POLE STACKING SHED

**Top quality shed combining security and looks. Ideal for storing and sorting up to 50 poles.**

Possibility of storing two full bundles.

8 pockets inside the door allow storage of tips and other small items of equipment

Doors open laterally. Dim. 5.40 x 0.70 x 1.05m.

Ref	Product description
15530	Pole shed for fixed ground installation
15535	Option of 4 swivelling wheels for pole shed



## EQUIPMENT SHED

Ideal for storing, protecting and stacking small equipment items near to their place of use.

Jack-operated door opening system.

Ref	Product description
15540	5 x 2 x 1.70 m - fixed ground installation
15520	5 x 2 x 1.70 m - with swivelling wheels



## FOAM PROTECTORS

**Essential if sports are to be taking place nearby.**

Made from polyethylene foam covered with a 1000 denier canvas.

Top attachment system using riveted flap.

Ref	Product description
15000001	Foam protector sold by linear metre - 1.20m height
40260080	Foam protector for shed corner, sold by sqm.

# ATHLETICS



Dima, as close as ever to grass-roots and users, has developed athletics activities packs with professionals.

As a partner to sports bodies, we offer you basic equipment to help children discover, learn and progress.

Products are suitable for use in schools and clubs.



## CLUB ATHLETICS BEGINNERS PACK

This comprehensive pack has been specially designed to introduce all athletics disciplines to children in the safest conditions and in a fun way. This pack is particularly well-suited to athletics clubs.

### Contents

1 set of school starting blocks, 1 set of GPP hurdles – width 60cm – adjustable 20-30cm, 1 set of GPP hurdles, width 60cm – adjustable 40-60cm, 1 set of relay batons, 1 multi-functional stopwatch, 1 set of 20 flat cones and their holder, 1 set of 20 stride indicators, 3 PVC skipping ropes, 1 hoop ladder, 1 set of 6 rubber hoops, 1 school rubber hammer 1kg, 1 set of weighted balls 200g, 1 set of 3 vortex javelins, 1 fibre glass 20m measuring tape, 1 free sports bag.

70107



## CLUB ATHLETICS BEGINNERS PACK/ THROWING

### Contents

1 set of flat cones diameter 20cm height 5cm, 1 target mat for throw landing zone, 3 foam javelins, 2 indoor rubber shots 2kg, 3 vortex javelins, 2 beginners PVC discs with handles 600g, 2 beginners PVC discs with handles 800g, 1 fibre glass 10-metre measuring tape, 1 sports bag.

70116



## CLUB ATHLETICS BEGINNERS PACK/ RUNNING

### Contents

1 set of 6 foldaway agility hurdles 15 and 30cm, 1 non-slip agility ladder length 12m, 1 set of adjustable multi-purpose hurdles with free transportation bag, 1 set of 20 non-slip rubber stride indicators, 3 pairs of beginner starting blocks, 1 fibre glass 10-metre measuring tape, 1 basic stopwatch.

70118



## ATHLETICS DISCOVERY PACK / THROWING

Perfect for discovery of throwing events, specifically devised for schools and clubs.

### Contents

2 foam javelins, 2 rubber hoops, 2 rubber shots 1kg, 2 rubber hammers 350g, 2 medicine balls 1kg, 1 set of flat cones height 5cm, 1 free sports bag.

70113



## ATHLETICS DISCOVERY PACK / JUMPING

Perfect for discovery of jumping events, specifically devised for schools and clubs.

### Contents

2 PVC foldaway training hurdles height 30cm, 2 PVC foldaway training hurdles height 40cm, 1 set of 12 flat rubber hoops, 12 cones height 35cm with holes, 6 rods 100cm, 1 10-metre measuring tape.

70114



## ATHLETICS DISCOVERY PACK / RUNNING

Basic equipment specifically devised for schools and clubs.

### Contents

1 agility ladder, 1 set of 6 relay batons, 1 set of 40 flat cones, 3 whistles, 1 stopwatch, 4 cones, 1 official's clipboard, 1 free sports bag.

70117



## ATHLETICS DISCOVERY PACK/MULTIDISCIPLINE

Perfect for discovery of multi discipline events, specifically devised for schools and clubs.

### Contents

1 stopwatch, 1 set of 3 vortex javelins, 1 foot speed ladder, 6 x 35cm cones with holes, 6 x 80cm rods, 1 set of tripod starting blocks, 1 official's clipboard, 1 free sports bag.

70115

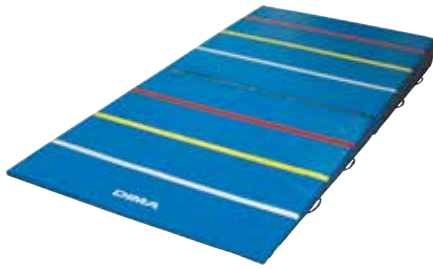

## LONG JUMP MAT

Ideal for teaching long jump to beginners in total safety. Foldable in two for easy storage. Made from polyethylene foam. Special non-slip underside. Colour graduations every 50cm. 8 carrying handles.

Ref	Product description
30231	200 x 100 x 20 / 4 cm (dim folded 100 x 100 x 24 cm)
30230	400 x 200 x 30 / 4 cm (dim folded 200 x 200 x 34 cm)



## 5-STEP FOAM STAIRS

Ideal for learning long jump, to aim to jump higher and further. Sturdy and stable. Made of two elements connected by Velcro flaps reinforced by a buckle and strap system.

Ref	Product description
30220	5-step foam stairs (3 x 1.50 m)



## TAKE-OFF MAT

Specially designed for vertical or horizontal take-off training. Made from polyethylene foam. Foldable in 5.

Ref	Product description
23900	



## SET OF 3 POLE VAULT MATS

Ref	Product description
11107	

## VERTICAL TAKE-OFF POST

Post on base with ball to practice vertical take-off. Built on a heavy base for maximum safety. Ball height adjustable to requirements using halyard. Post height: 3m

Ref	Product description
23905	Vertical take-off post

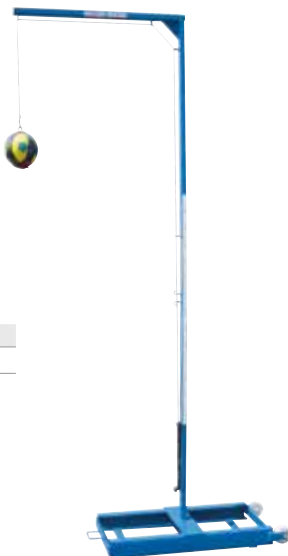

## CROSS MAT

For play. Made from polyurethane foam covered with a 1000 denier PVC cover, non-slip underside. (Phthalate-free covering.)

Ref	Product description
23940	Cross Mat 150 x 150 x 1.5 cm



## THROWING AREA

Easy to install and ideal for fun throwing practice. Throwing area in a 1,000 denier PVC fabric, in bright colours with metric measurements. Foam end edge to stop the equipment. Throwing circle with a circle mat secured to the throwing area using velcro strips. Dimensions: 8 x 5m

Ref	Product description
11108	Dimensions : 8 x 5 m

## SET OF TARGET HOOPS

Kit offering a host of combinations to develop motor skills and throwing proficiency. Comprising 3 hoops of 75cm diameter, 6 base blocks, 6 x 1.80m poles and 6 fixing clips.

Ref	Product description
10190	Set of 3 target hoops



## VERTICAL TARPULIN TARGET FOR THROWING - 130 x 130cm

With coloured circles and eyelets, can be hung vertically.

Ref	Product description
70098	Tarpaulin target



## TARPULIN TARGET FOR THROWING EVENT LANDING AREA - 300 x 100cm

With colour coded zones for easier identification

Ref	Product description
70097	Throwing event landing area



# DIMASPORT

SPORTS EQUIPMENT

## MANUFACTURER

WE MANUFACTURE OUR PRODUCTS IN OUR FACTORIES NEAR PARIS.

### METALWORK

We cut, drill and weld the steel ourselves.  
Every production stage is rigorously controlled.



**MADE IN**  
OUR FACTORY  
IN PARIS REGION

### TARPAULINS

For over 50 years, we have been constantly improving our processing methods to offer top-quality products.



**Our suppliers** are firms with whom we have been working for many years and with whom we develop our products. We remain scrupulously attentive to their quality.

### RAW MATERIALS



Our foams are of the highest quality and we know their composition.

Our canvases are inspected and certified.

We select our steels carefully and we know where they come from.

We require unremittingly high standards from our suppliers, because the quality of our raw materials largely guarantees the quality of our products.

RESPONSIBLE FOR PRODUCTION  
TO FULFIL **YOUR SATISFACTION**  
**TOTAL COMMITMENT FROM DIMA**



## DIMA, INVENTOR OF SPORTS EQUIPMENT

### CREATOR

CLOSE TO GRASS-ROOTS NEEDS, WE REMAIN ATTENTIVE TO YOUR REQUIREMENTS AND REGULARLY BRING OUT NEW PRODUCTS.

Steps with round edges at the request of trainers, starting sleds specifically designed to pass over starting blocks, solid and well-adjusted resistance training belts... the list goes on.

Because all sports require daily **physical training sessions**, Dima offers products that are perfectly suited to improving **flexibility, explosive power, core strength and footwork and speed.**

## CONTENTS

# TRAINING / DRILLS

Jumping.....	64
Strengthening.....	66
Hurdles.....	68
Pedagogym.....	71
Marking equipment.....	72
Training kits.....	78
Storage.....	80

# TRAINING / DRILLS



## GPP STACKING BENCHES

Set of 4 GPP (General Physical Preparation) stackable benches for plyometric workouts. Steel legs and base, non-slip wooden surface 15mm thick (synthetic optional). Measurements (Length x width x height) : 1 bench 89 x 64 x 60cm, 1 bench 81 x 56 x 50 cm, 1 bench 73 x 48 x 40cm and 1 bench 65 x 40 x 30cm

Ref	Product description
10777	Set of 4 GPP Stacking benches



## STANDARD GPP BENCHES

Standard GPP (General Physical Preparation) Benches available in different heights. Steel base, non-slip wooden surface (synthetic optional). Dimensions (Length x width) 80 x 55cm.

Ref	Product description
10770	Height 10cm
10771	Height 20cm
10772	Height 30cm
10773	Height 40cm
10774	Height 50cm
10775	Synthetic Option



## WOODEN GPP STEPS

Well manufactured Wooden GPP (General Physical Preparation) Steps. Specially designed for training. Made from wooden structure 15mm thick, synthetic covering with rounded edge down to ground allowing for worry-free and safe jumping and push-offs.

Ref	Product description
10762	120 x 40 x 5cm
10761	120 x 40 x 10cm
10760	120 x 40 x 20cm



## SET OF 3 PLYOMETRIC BENCHES

Stackable benches, height 20, 30 and 40cm.

Ref	Product description
10750	Set of 3 plyometric benches



## ROUNDED STEEL BENCH

Made from steel, very stable. Helps to improve explosiveness. Synthetic covering. Dim. 120 x 75 x 20cm

Ref	Product description
10765	Rounded Steel Bench

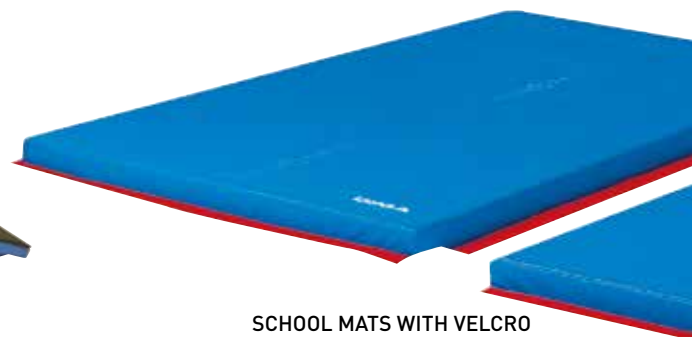

## SCHOOL MATS WITH VELCRO ATTACHEMENTS ON 4 SIDES

Can be joined to make a working area or used individually.

Ref	Product description
23590	School mats



## PLYOMETRICS FOAM BLOCK

For plyometric training. Composition: Polyurethane foam. 17kg/m<sup>3</sup>. Covered with 1000 denier Tergal fabric. Dim : 120x120x60cm

Ref	Product description
70038	Plyometrics foam Block



## GPP MAT

Perfect for stretching and ab work. Made from dense polyethylene foam, 3cm thick. Non-slip underside. Washable. Folds in two, easily stocked and transported. Opened dimensions: 100 x 50 x 3cm. Folded dimensions: 50x50x6cm

Ref	Product description
23951	General Physical Education Mat

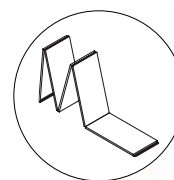

## CLASSIC TRACK WITH VELCRO END STRAPS

These dense foam surfaces offer firm and dynamic properties to allow high-quality and safe footwork exercises for joints and tendons or standard limbering up exercises.

Ref	Product description
22360	600 x 100 x 50.5
22310	1000 x 100 x 5.5 cm





## SWEDISH BENCH

Ideal for club and school use. Swedish bench made from varnished laminate layers. Well-finished corners, danger-free for users. Non-slip rubber-finished feet.

Ref	Product description
banc2	Swedish bench 2m
banc3	Swedish bench 3m
banc4	Swedish bench 4m

## WALL BARS

Ideal for use in schools and clubs. Wooden wall bars, knot-free for greater solidity. Compliant with standard EN 12346. Highly shock-resistant and no risk of warping. Can accommodate our range of Swedish benches.

Ref	Product description
espa1	Basic Wall Bars - 240 x 90cm
espa2	Double Wall Bars - 250 x 168cm



## TRACTION BAR FOR WALL BARS

Can be hung on the bars at several heights for multiple exercises. Metal and wood construction. Can support up to 120kg.

Ref	Product description
ESPAB	Traction Bar for Wall Bars



Ref 14952



## GYMNASTIC MATS

Ref	Product description
14945	140 x 60 x 0.8cm (Set of 10)
14950	180 x 60 x 0.8cm (Set of 10)
14951	Gym Mats Mobile Rack (80 x 60 x h 200cm)
14952	Wall Support for Gym Mats.

Ref 14951



## PUSH UP BARS

Renders pumping exercises more effective.

Ref	Product description
70060	Push Up Bars (set of 2)
70065	Push Up Performance Bars (set of 2)



## SKIPPING ROPES

Ref	Product description
10370	PVC with Handles - Length. 280cm
10369	Cotton, no Handles - Length. 305cm

## CROSS MAT

For fun athletics practice. Many uses for this product. (Numbered 0 to 4). In polyurethane foam, covered with 1000 denier PVC cover, non-slip underside.

Ref	Product description
23940	Cross Mat 150 x 150cm



# TRAINING / DRILLS



## MEDICINE BALL

Made from synthetic material, constant pressure.

Ref	Product description
21300	1kg - per unit
21310	1.5kg - per unit
21320	2kg - per unit
21330	3kg - per unit
21340	4kg - per unit
21350	5 kg - per unit



## MEDICINE BALL BELT

Ref	Product description
21370	Support Belt



## MEDICINE BALL WITH HANDLE

Perfectly suitable for children due to its ergonomic handle, for more accurate movement learning.

Ref	Product description
21354	1kg - per unit
21364	2kg - per unit
21366	3kg - per unit
21374	4kg - per unit



## ÄO-HANDLED MEDICINE BALL

Ref	Product description
21206	6kg
21207	7kg
21208	8kg



## VERTICAL RACK FOR MEDICINE BALLS

Capacity up to 5 medicine balls depending on size. Supplied unassembled.

Ref	Product description
SC101	Vertical rack for medicine balls



## KETTLEBALL

Ref	Product description
21404	4kg - per unit
21406	6kg - per unit
21408	8kg - per unit
21412	12kg - per unit
21416	16kg - per unit
21424	24kg - per unit
21432	32kg - per unit



## DIMA WEIGHTED VEST

Made from 1000 denier PVC fabric, very solid and designed to follow the forms of the body, leaving the arms free for movement and enhanced comfort. Easy to set up, adjustment by Velcro belt. Weight load up to 10kg, kilo by kilo. Weights supplied. **Other sizes on request.**

Ref	Product description
70051	DIMA weighted vest Size M
70052	DIMA weighted vest Size L



## WRIST AND ANKLE WEIGHTS

Comfortable for both wrists and ankles. Weighted bands made from Lycra with convenient steel buckles and Velcro straps. Sold by the pair.

Ref	Product description
70034	500g
70028	1kg
70022	1.5kg
70023	2kg



## WEIGHTED GLOVES

500g weighted gloves, sold by the pair. Both comfortable and strong.

Ref	Product description
70031	Weighted gloves (set of 2)



## WEIGHTED VEST

10kg weighted nylon vest. Weights from 0 to 10kg.

Ref	Product description
70055	Weighted vest



## STAND FOR EXERCISE BALL

For greater stability and safety, made from polypropylene, diameter 50cm.

Ref	Product description
10365	Exercise ball stand

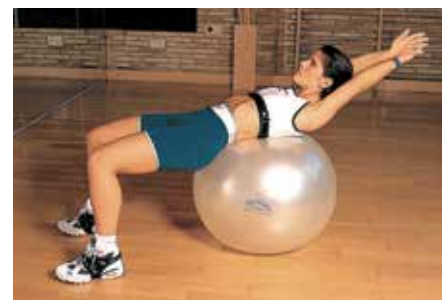

## EXERCISE BALL

Inflatable ball in solid PVC. Can support weights of 300kg and has a "warmer", and therefore more pleasant, handling surface.

Ref	Product description
10367	Ball Ø 55cm
10366	Ball Ø 65cm
10368	Ball Ø 75cm



### RESISTANCE BELT WITH HANDLE

Comprising a resistance training belt and 6 metres of elastic resistance cord. Two handles fixed at one end to allow the trainer to hold back the athlete.

Ref	Product description
70036	Resistance Belt (sold individually)



### JUMPING RESISTANCE BELT

Supplied with a belt and two elastic resistance cords fitted with specially-designed ends for guaranteed support.

Ref	Product description
70037	Jumping resistance belt



### RESISTANCE CORD WITH HANDLES

Elastic tube with 2 handles for easy handling. Length: 80cm

Ref	Product description
70035	Resistance cord with handles



### RESISTANCE / SPEED CORD

The reference in speed resistance training. Made from parablond (surgical rubber), both extensible and resistant. Used extensively in the medical and physiotherapy fields.

Ref	Product description
9ATEL004	Resistance/speed cord - 12.5m



### DUAL RESISTANCE TRAINER

Comprising 2 resistance belts and 12.50m of highly extensible parablond tube (medical rubber).

Ref	Product description
70011	Dual resistance trainer



### RESISTANCE BELT (STANDALONE)

Wide belt attaching by Velcro, fits the waist perfectly. Fitted with a ring on which to attach bungee or parablond cord (not supplied).

Ref	Product description
70010	Size M
70012	Size XL



### BUNGEE CORD

25 metre reel - Ø 6mm.

Ref	Product description
10560	Bungee cord



### ANKLE RESISTANCE STRAPS

Easy fitting with Velcro straps. Fitted with ring for attachment of bungee cord. Sold by pair

Ref	Product description
70032	Ankle resistance Straps (set of 2)



### ANKLE WEIGHTS

Easy fitting with Velcro straps. 1kg weight.

Ref	Product description
70030	Ankle Weights (set of 2)

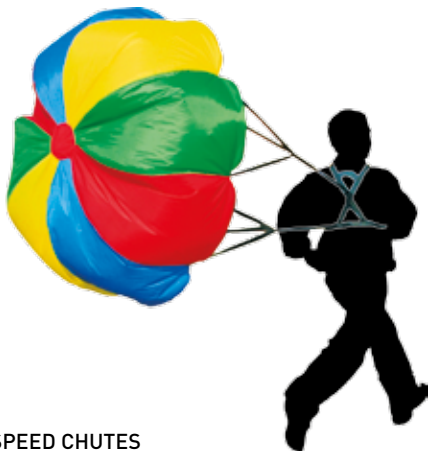

### SPEED CHUTES

For physical condition work. Easy to set up with Velcro.

Ref	Product description
50001	Size S (100cm)
50002	Size M (120cm)
50003	Size L (140cm)



### POWER SLED

For power exercises.

Weighed down by 28mm diameter cast iron disc (not supplied). Delivered with a 10-meter strap harness. The "Special Start" model allows travel from the starting blocks.

Ref	Product description
70015	Standard Power sled
70016	Special Start power sled (140cm)



### ELASTIBAND

Versatile. The Elastiband can be used on each of the main muscle groups (arms, back, glutes, pecs, thighs, abs, etc.). Anti-tear and non-deforming. 39% elastodiene, 35%polyester, 26% polyamide. Washable at 30°C maximum. Can be used in aquagym activities. Fitted with handles for hands/feet.

Ref	Product description
70048	Elastiband - resistance 10kg
70050	Elastiband - resistance 15kg
70049	Elastiband -resistance 20kg

# TRAINING / DRILLS

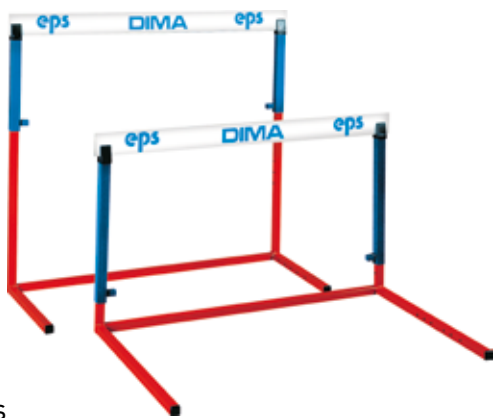

## SCHOOL HURDLES

Genuine hurdles, perfect for beginners or footwork. Sturdy and easy to handle, Lacquered steel construction, supplied with protective rubber end pieces. The PVC hurdle board is set on rubber supports for greater safety and less apprehension. Automatic height adjustments using hidden ball plunger system.

Heights: 55 - 60 - 65 - 70 - 76 - 84 - 91 - 96 - 99 - 106 cm - Width: 1m

Ref	Product description
10330	Set of 3 school hurdles
10336	Set of 6 school hurdles
10320011	Rubber support for school and mini hurdle boards
10380	Replacement hurdle board for school and mini hurdles



## FOAM HURDLE MAT

Made from thick foam, this product provides total safety and eliminates any fears. Provided with end velcro strips, the assembly of these mats achieves a very flat surface (like a gym mat surface) for footwork, coordination, or gymnastic exercises.

Ref	Product description
23936	Set of 4 folding hurdle mats 35cm. Yellow. Dim. unfolded: 100 x 70 x 4cm
23941	Set of 4 folding hurdle mats 50cm. Blue. Dim. unfolded: 100 x 100 x 4cm
23946	Set of 4 folding hurdle mats 65cm. Red. Dim. unfolded: 100 x 130 x 4cm

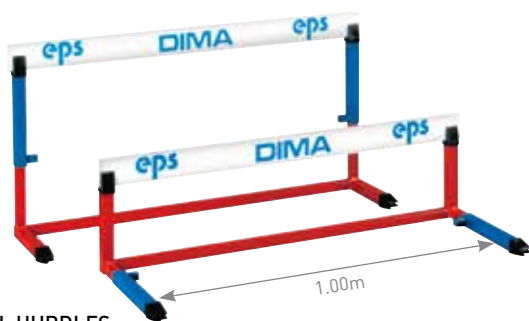

## MINI SCHOOL HURDLES

Same design as school hurdles.

Ref	Product description
10230	Set of 3
10236	Set of 6
10320011	Rubber support for school and mini hurdle boards
10380	School PVC Hurdle Boards



## MINI OBSTACLES

Ideal for track work. Can be piled on top of one another. Polyurethane foam covered in a 1000 denier Tergal fabric. Supplied with a free storage bag.

Ref	Product description
10345	Set of 8 Red Mini Obstacles 50 x 12 x 12cm
10346	Set of 8 Yellow Mini Obstacles 50 x 18 x 18cm



## "OLIVER" SPECIAL EDUCATIONAL HURDLE

Hurdle ideal for training due to its lightness and no L-shaped supports. Allows lateral training without risk of sprains. Steel construction with an epoxy lacquer surface treatment. Specifically developed for training groups. Instant height adjustments using a ball & spring system. PVC hurdle board. Adjustable heights: 65 - 76 - 84 - 91 - 99 - 106cm

Ref	Product description
10301	Special Educational Club Hurdle (set of 5)
10310	PVC Hurdle Board - I.A.A.F certified



## CROSS-BRACED HURDLES

Lightweight and easy to set up. Made of aluminium. PVC hurdle boards 100cm wide. Supplied with free storage bag.

Ref	Product description
10239	Set of 6 cross-braces hurdles with bag
10239001	Hurdle board for cross-braced hurdle – sold by unit

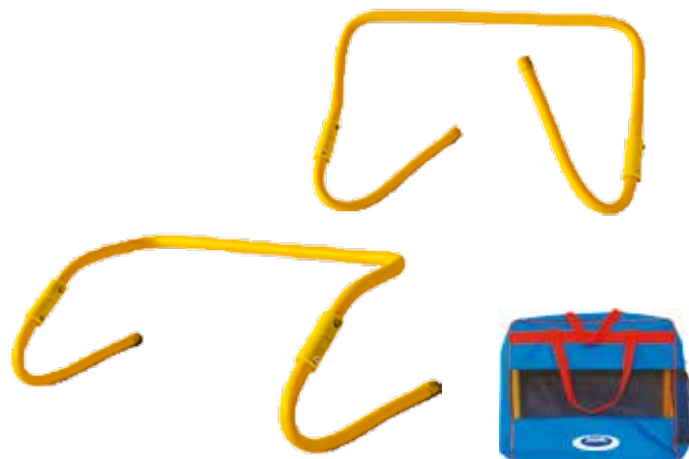

## FOLDABLE VARIABLE HEIGHT STEP HURDLES

Lightweight and easy to transport due to its flat folding system. Ideal for footwork and trackwork. In tubular PVC. 15 or 30cm height. Supplied with a free storage bag.

Ref	Product description
10234	Set of 6 Hurdles with Storage Bag



## ADJUSTABLE GPP FOAM HURDLES

Easy to set up and carry. Perfect for travelling athletes.

Ref	Product description
10339	Set of 5 hurdles

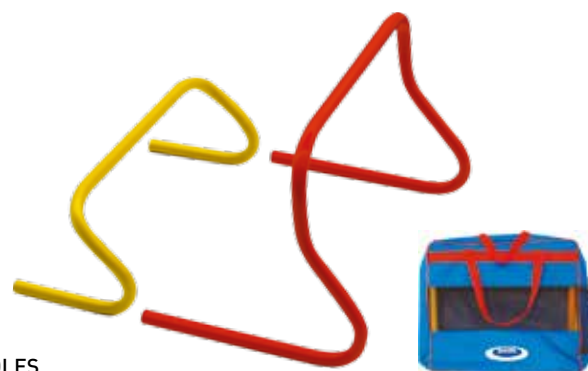

## STEP HURDLES

Lightweight and easy to transport. 45cm width. Ideal for footwork and trackwork. Supplied with a free storage bag.

Ref	Product description
10232	Set of 6 - 15cm height
10233	Set of 6 - 30cm height
Step Hurdles Transportation Strap	
10237	Transportation Strap

## FOAM HURDLE

Stable and totally safe.

(Width: 100cm - Height: 40cm) Thickness: 7cm above and 25cm below.

Ref	Product description
10340	Foam Hurdle



## BABY HURDLES

Adjustable heights:

25 - 30 - 35 - 40 - 45 - 50 - 55 - 60cm.

60cm width.

Ref	Product description
10235	Set of 3 Baby Hurdles
10238	Set of 6 Baby Hurdles
10235002	Replacement PVC crossbar (Set of 5)

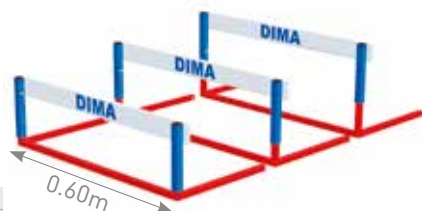

## DIMAKID HURDLES

Strong, easy to use and to stack. PVC hurdle boards placed on rubber supports. Supplied with a free storage bag.

Ref	Product description
10350	Set of 6 Dimakid Hurdles - 20cm height
10355	Set of 6 Dimakid Hurdles - 40cm height
10360	Mixed set of 6 Dimakid Hurdles (20 et 40cm)

# TRAINING / DRILLS



## GPP HURDLES

Perfect for beginners. Adjustable height from 20 to 30 cm. PVC tube and joints. Can be fully dismantled. Lightweight. Width 60 cm.

Ref	Product description
10333	Set of 3 - height 20-30 cm
10334	Set of 3 - height 40-60 cm



## PVC TRAINING HURDLES

Perfect for beginners. Safe and easy to dismantle.

Ref	Product description
10331	Set of 3 - Adjustable from 40 to 60 cm
10337	Set of 3 - Adjustable from 55 to 95 cm
10332	Set of 6 - Adjustable from 40 to 60 cm



## FOLDABLE TRAINING HURDLE

Lightweight and easy to transport and install. PVC Hurdles. Ideal for indoor training.

Ref	Product description
10323	Set of 10 - 20cm height
10324	Set of 10 - 30cm height
10325	Set of 10 - 40cm height
10326	Set of 10 - 50cm height



## ALUMINIUM AUTO RETURN HURDLES

A hurdle that stands back up on its own, allowing for greater training frequency. Its all-aluminium design makes it an easily-transportable education aid, perfect for teaching schoolchildren indoors or outdoors. Fast adjustment of high using ball and spring system. (40, 45, 50, 55 and 60cm). Width: 1.00m.

Ref	Product description
10210	Set of 3 Aluminium auto-return hurdles



## SYNTHETIC TRACK ROLL

Training Synthetic Track Roll, suitable for points. Black, Thickness 12mm, 1.25m width.

Ref	Product description
13162	10 x 1.25m track roll
13163	Linear metre

Training Synthetic Track Roll, suitable for points. Black, Thickness 6mm, 1.25m width.

Ref	Product description
13172	10 x 1.25m track roll
13173	Linear metre

Mondo Synthetic Track Roll, suitable for points. Red, Thickness 12mm, 1.22m width.

Ref	Product description
13161	15 x 1.22m track roll
13160	Linear metre

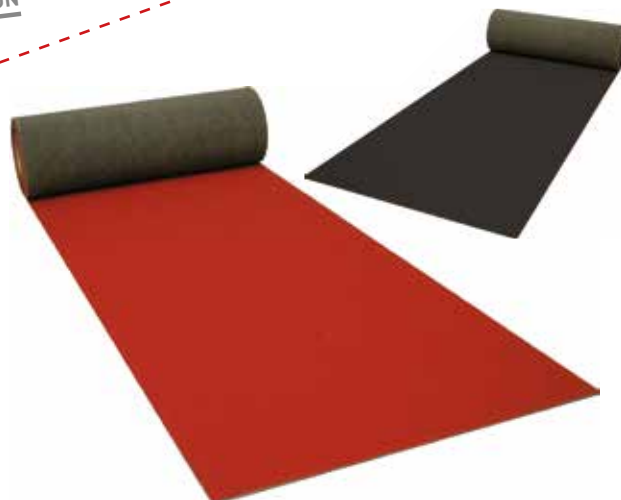



**FOAM ROLL**

Made from dense foam. Perfect for stretching and school training.

Ref	Product description
14330	Foam roll: length 1m diam 80cm

**PEDAGOGYM**

These versatile foam elements can be used for specific stretching and physiotherapy exercises. Block, broken wedge, cylinder, incline, stabilised cylinder, platform, 2-part rectangle.

See description pages 12-13 - section gymnastics



BLOCK



BROKEN WEDGE



INCLINE



STABILISED CYLINDER



CYLINDER



2-PART RECTANGLE



PLATFORM



**DIMA TIPS**  
What to do with...  
FOAM ROLL

Ref 14330

**EXERCISES FOR HURLERS**

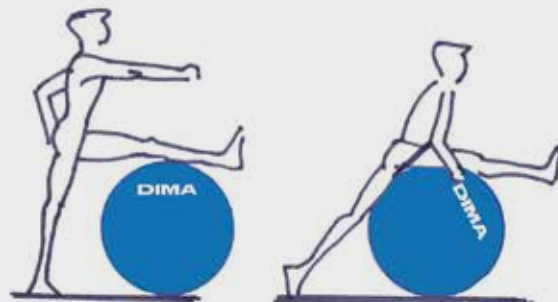

SPECIFIC SUPPLENESS OF LOWER LIMBS

SPECIFIC SUPPLENESS OF HIPS AND ARM-LEG SYNCHRONISATION



**GYMNASTIC MUSCLE STRENGTHENING**



ABDOMINAL WALL



BACK MUSCLES

## A SUPPLIER THAT LISTENS AND ADVISES YOU

AT DIMASPORT YOU WILL ALWAYS BE ABLE TO FIND A SPECIALIST:

### A TEAM AT YOUR SERVICE

to offer you advice and support in choosing your equipment.

Specialists in sports equipment, we help you choose what best suits your requirements, from beginners to competition level.

#### CONTACT OUR TEAM OF ADVISORS

Tel. +33(0)1 64 40 05 70

E-mail: [info@dimasport.fr](mailto:info@dimasport.fr)

Fax: +33(0)1 64 40 00 37

## ORDERING WITH DIMASPORT COULDN'T BE EASIER:

**1** Prepare your order on [www.dimasport.fr](http://www.dimasport.fr)  
All of our catalogues are available online.

**2** Place your order.  
Send your order request:

**BY FAX: +33(0)1 64 40 00 37**

**BY PHONE: +33(0)1 64 40 05 70**

**BY E-MAIL:**  
[info@dimasport.fr](mailto:info@dimasport.fr)

**BY POST:**  
1 bis rue Louis Armand  
BP 91  
77834 Ozoir-la-Ferrière cedex  
FRANCE

**Dimasport guarantees you top quality service:**

- Step-by-step order tracking
- Worldwide deliveries
- Specialist aftersales service.



#### FLAT CONES

To define an area. Boundary cones made from hard rubber. Supplied with steel stand (for ref. 10496 and 10497) with shape allowing insertion of a rod. Assorted colours.

Ref	Product description
10495	Set of 20 - Ø 20cm - height 5cm
10496	Set of 40 - Ø 20cm - height 5cm
10497	Set of 20 - Ø 30cm - height 20cm

#### TRANSPORTATION STRAP

To carry your flat cones easily.

Ref	Product description
10498	Flat Cones carry strap.



#### MULTI-FUNCTIONAL CONES HURDLES

20 cones + 10 x 1 metre rod with free storage bag.

Ref	Product description
10403	Set of 10 - Height 5cm
10404	Set of 10 - Height 20cm



#### METRIC TAPE

In unwoven fabric. Very light and easy to position. 17cm.wide. Markings every 20cm.

Ref	Product description
10390	20m. tape
10395	50m. tape



#### VELCRO ELASTIC TAPE

Brightly-coloured tape for a range of activities. Can be used in place of a high jump crossbar, a goal crossbar, a tennis or badminton net. Elastic tape 5cm wide which can be extended from 3 to 5m.

Ref	Product description
10580	Elastic tape with velcro





**MULTI-PURPOSE HOLED CONES WITH SLOTTED TOPS**

Ideal for setting up your infant agility course. These multi-purpose marker cones have holes in which you can insert rods, and two slots in the top points to fit flat hoops, thus offering a wide range of combinations. Circular base, no sharp edges, for maximum safety.

Ref	Product description
K5010	Set of 4 - 37cm - 4 colours
K5015	Set of 4 - 50cm - 4 colours



**MULTI-FUNCTIONAL CONE HURDLES**

Ideal for training for all types of sport. Each hurdle comprises one 1-metre rod and two 12-hole cones (37 or 50cm). Supplied with free storage bag.

Ref	Product description
10415	Set of 3 - Adjustable height 7, 20, 32cm
10416	Set of 3 - Adjustable height 9, 24, 39cm



**SOFT RUBBER CONES HEIGHT 18CM**

For total safety.

Ref	Product description
10480	Set of 12 Soft rubber Cones



**MULTI-ACTIVITY PACK**

Specially designed, our packs are scalable and offer basic equipment for training. Dima offers easy-to-use, adaptable and safe products. Contents of a multi-activity pack: 2 x 37cm 12-hole cones - 2 x 100cm rods Ø 25mm - 1 x 120cm rod Ø 25mm - 1 pair of rotating clips for rods - 2 flat hoops Ø 60cm.

Ref	Product description
10406	1 multi activity pack
10407	4 multi activity packs with free bag



**30CM CONES NUMBERED 5 TO 40**

Numbered 5, 10, 15, 20, 25, 30, 35 and 40

Ref	Product description
10486	Height 30cm - set of 8 cones



**PVC CONES 17 OR 37CM**

Ideal for your agility courses, dribble drills, attack and defence exercises, all-sports training sessions.

Ref	Product description
10485	Set of 12 PVC Cones Height 17cm
10490	Set of 12 PVC Cones Height 37cm

# TRAINING / DRILLS

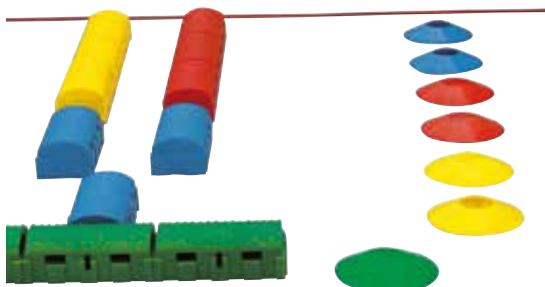
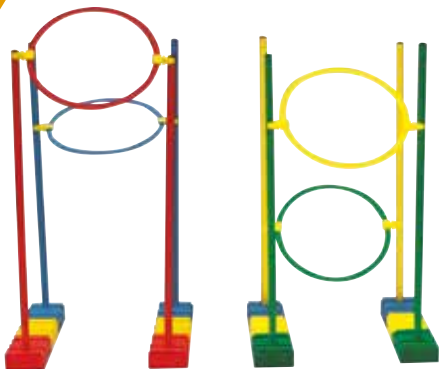

## MOBILITY COURSE EQUIPMENT

Ideal for setting up your mobility courses. Contents: 24 multi-game bricks, 12 top bricks, 4 flat hoops (40 – 50 – 60 – 70cm diameters), 8 x 100cm rods, 4 pairs of rod/flat hoop clips, 20 multi-game mini markers, 1 x 250cm. vinyl tape, 1 x 90 x 110cm storage bag – Assorted colours

Ref	Product description
K5070	Course Equipment

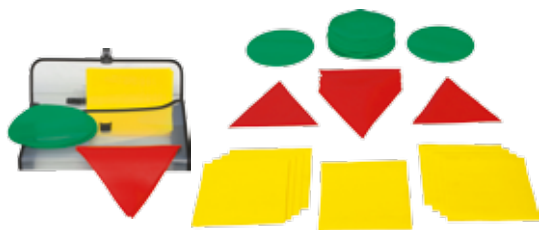

## FLOOR MARKINGS

Ideal for setting up your mobility courses. The various components, made of soft, thick and solid vinyl, adhere perfectly to the floor, delineating course zones, giving structure to playing areas and providing reference markers. Different colours: red, blue, green, yellow.

Ref	Product description
K5085	10 round slabs, 10 square slabs, 10 triangular slabs

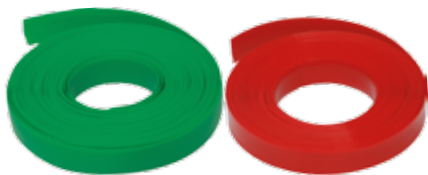

## VINYL TAPE

Usable indoors and outdoors to mark play and work areas. Can be cut to make stride indicators. Composition: In soft PVC. 4cm. width. Various colours.

Ref	Product description
10373	Vinyl tape 10m
10374	Vinyl tape 20m

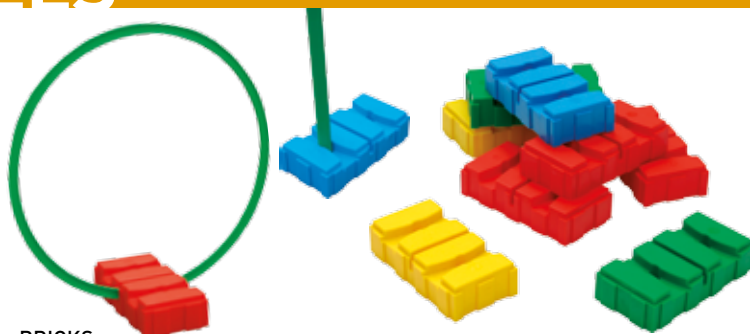

## BRICKS

Ideal for setting up your mobility courses. These bricks can be stacked, clipped together and hold rods and flat hoops, offering a host of different combinations. Coarse surface to enable barefoot use.

Ref	Product description
K5045	Set of 12 bricks
K5051	Set of 12 brick tops



## SET OF 20 STRIPS + 12 ARROWS + 4 CORNERS + 12 CURVES

Ideal for setting up your mobility courses. The various components, made of soft, thick and solid vinyl, adhere perfectly to the floor, delineating course zones, giving structure to playing areas and providing reference markers. Different colours: red, blue, green, yellow.

Ref	Product description
K5090	Set of 20 strips + 12 arrows + 4 corners + 12 curves



## SET OF 10 HANDS + 10 FEET

Ref	Product description
K5095	Set of 10 hands + 10 feet

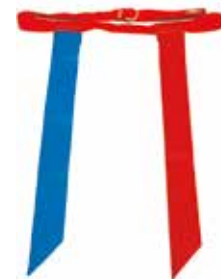

## VESTS

Vests in light nylon fabric (numbered) with elastic side bands. Ideal for distinguishing teams during games. Measurements : 56 x 31 cm.

Ref	Product description
Hock650	Set of 12 (6 yellow + 6 red)
Hock651	Set of 12 (6 blue + 6 green)

## FLAG BELTS

Ideal for team games. Belt adjustable with Velcro straps.

Ref	Product description
K5056	Set of 5

## TIPS

### What to do with... STRIDE INDICATORS

Ref 10372



#### STRIDE INDICATOR

Made of anti-skid rubber. Marked both sides. Dimensions 50 x 5cm

Ref	Product description
10372	Set of 20

#### FOOT SPEED LADDER

Length: 8.50 m. Width: 50cm. Possibility to join up several ladders using an attachment system. Adjustable spacing.

Supplied with a free storage bag.

Ref	Product description
10377	8.5m Foot Speed Ladder

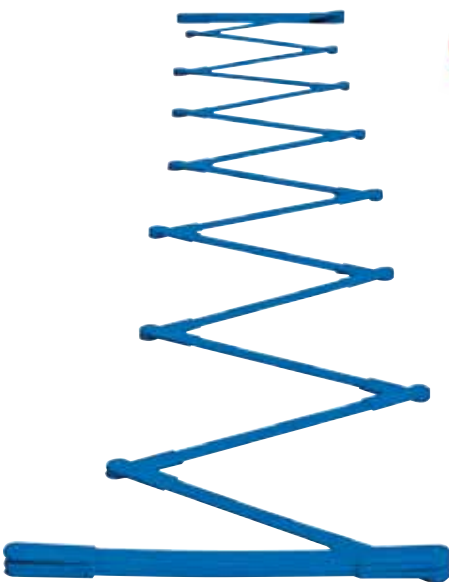

#### AGILITY LADDER

Allows for organisation of space and the programming of rhythm exercises. Flexible spacing. Very easy to position. Lightweight and easy to use. Possibility to form a circle. Made from anti-slip rubber. Rung lengths: 60cm. **Supplied with free storage bag.**

Ref	Product description
10381	Agility Ladder



#### RUN ON A STRIDE TRACK (ST)

TO IMPROVE RUNNING SPEED  
BY CONTROLLING A RANGE  
OF STRIDES

IN FAST STRIDES (FS), with stride frequency

IN POWERFUL STRIDES (PS), with stride distances.

Stride tracks (ST) are made up of stride indicators laid down at equal distances between which the runner may only touch down once!

1st touch point  
for FS Fast Strides

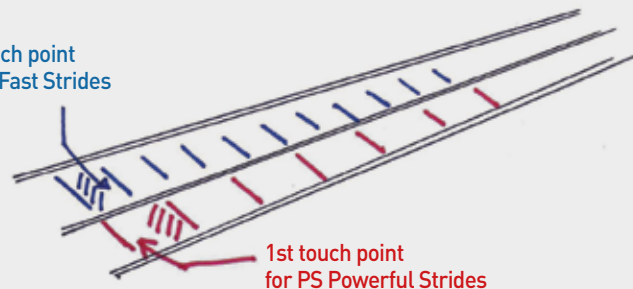

#### VARIATIONS

- 2 identical parallel lanes, with a head-to-head race with a similar athlete... BUT NO ERRORS ALLOWED!
- ST with change of rhythm: the change of stride indicator colour means the change of their distancing, meaning the athlete has to go from FS to PS, WITHOUT SLOWING DOWN!
- Establishment of Optima stride (OS) – the best compromise between FS and PS, and to be targeted by timing a 20m stretch from a flying start. This is also the best way of working out the last 4 or 6 strides before the take-off board (in long jump and triple jump).



	Fast strides FS	Optima strides OS	Powerful strides PS
10-12 years	0.80m to 1.00m	1.40m to 1.55m	1.60m to 1.75m
14-15 years	1.00m to 1.20m	1.50m to 1.70m	1.75m to 2.00m
17-18 years	1.40m to 1.50m	1.65m to 1.85m	1.90m to 2.10m
Top level, women	1.80m to 2.00m	2.10m to 2.25 m	2.30m to 2.45m
Top level, men	2.10m to 2.25m	2.30m to 2.45m	2.50m to 2.70m

## TIPS DIMA

### What to do with... STRIDE INDICATORS

Ref 10372

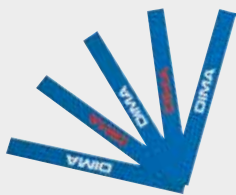

### CALCULATE YOUR MAXIMUM SPEED IN KM/H OVER 20M FLYING START

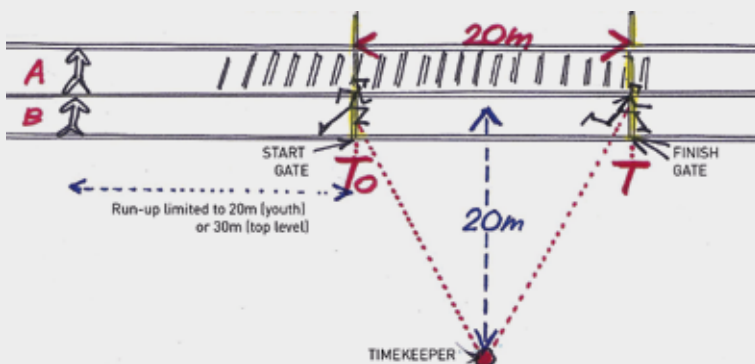

- The timekeeper must always stand on the same spot, perpendicular to the track and 20m away from it.
- The stopwatch is started (T0) and stopped (T) of the stopwatch happen when the torso passes through the start and finish gates respectively, made up of 2 vertical poles.
- Manual timekeeping is reliable and accurate without requiring expertise, whereas photo-electronic cells can produce erratic results due to being set off by limbs or not being adjusted to the body sizes of young people.
- **Track B**, free strides – **Track A** race on stride track for the calibration of a FS – OS – PS drill.

#### Several tips for and benefits from this exercise

- Start off gradually. It is pointless and tiring to get up to maximum speed before the start gate.
- Decelerate gradually after the finish gate.
- Games: pair up runners 2 by 2 according to times achieved so as to organise duels with well-matched opponents on 2 adjacent lanes with free or imposed stride patterns.

#### Calculate your flying start speed in km/h

- 20m with flying start in 3s equates to 24km/h.
- 20m with flying start in 2.50s equates to 29km/h.
- At top level, Jacques Piasenta has only trained three female athletes capable of running 20m in 2 seconds (36 km/h)! They could run 100m in under 11 seconds.
- Usain Bolt, when setting his 100m world record, ran from 60 to 80m in 1.61s, a speed of 44.72km/h.

# TRAINING / DRILLS

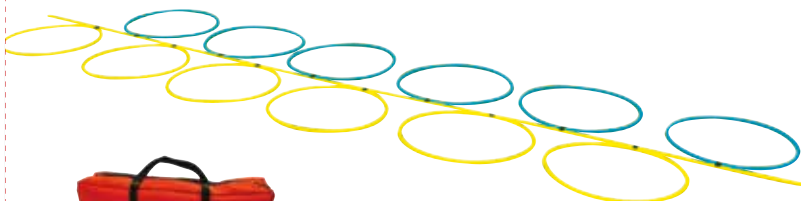

#### AGILITY HOOP LADDER

Ideal for varying lessons. Comprised of 8 x 60cm. rods, 12 x 60cm diameter round hoops and 12 clips. Delivered with a free storage bag.

Ref	Product description
K5206	Agility Hoop Ladder

#### HOOP LADDER

Comprised of 12 hoops Ø 50cm. Delivered with a free storage bag.

Ref	Product description
K5205	12 Hoop Ladder with bag

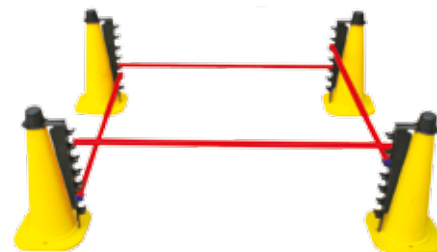

#### MULTI-HEIGHT MINI HURDLES

Ideal for defining your pitch. 8 x 45cm blocks, 4 x 1m rods, and 8 sliders in rigid PVC, adjustable from 10 to 40cm using a 7-position peg. Delivered with a free storage bag.

Ref	Product description
10405	Set of 4 Mini Markers

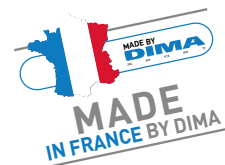

#### MULTI-PURPOSE TRANSPORTATION CART

Ref	Product description
10107	Multi-purpose transportation cart



**FLAT HOOPS**

For a range of games and offering a host of combinations. Idea for mobility courses. These flat hoops made from high-resistance nylon are designed to fit onto cones and blocks. Sold individually.

Ref	Product description
K5020	Ø 35cm
K5022	Ø 50cm
K5025	Ø 60cm
K5026	Ø 70cm



**HOOP BAG**

Made from canvas, ideal for carrying hoops of all sizes.

Ref	Product description
Sc67	Hoop Bag - Ø 35 to 50cm
Sc68	Hoop Bag - Ø 60 to 70cm

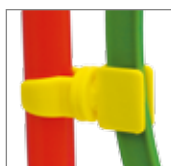

Ref K5040



Ref K5041

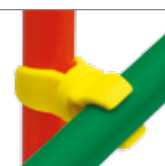

Ref K5042

**ROTATING POLE CLIPS**

Clips with rotating joints for wider flexibility of use. Set of 12.

Ref	Product description
K5040	Pole Clip for Ø 25 mm pole + flat hoop (Set of 12)
K5041	Pole Clip for Ø 25 mm pole + hula hoop (Set of 12)
K5042	Pole Clip for Ø 25 mm pole + Pole (Set of 12)



Ref 10195



Ref 10192

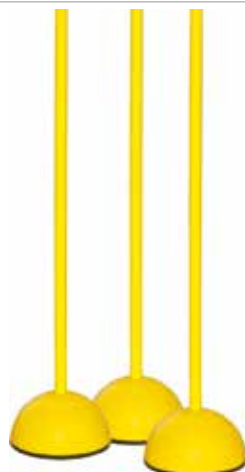

**BASES FOR POLES**

Ref	Product description
10195	Rigid Bases, requiring weighing down (set of 2)
10192	Weighted Bases 1.250 kg, in rubber (set of 2)

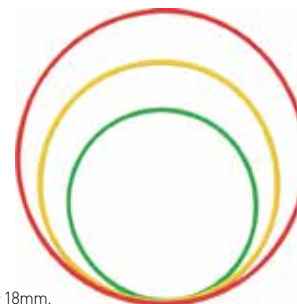

**HULA HOOPS**

Made from polyethylene tubes, diameter 18mm.

Ref	Product description
10196	Ø 50cm
10197	Ø 75cm

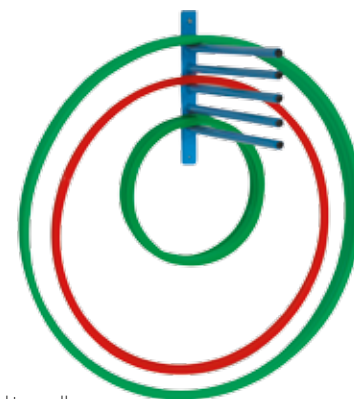

**HOOP WALL BRACKET**

Ideal for storing hoops. Made from steel, to be fixed to a wall. 5 arms 45cm long. Can hold up to 100 hoops according to diameter.

Ref	Product description
10198	Hoop Wall Bracket

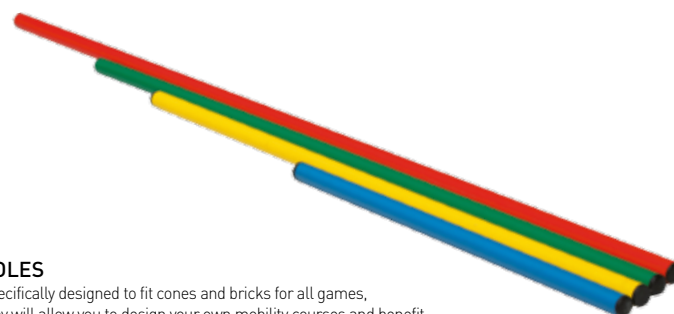

**POLES**

Specifically designed to fit cones and bricks for all games, they will allow you to design your own mobility courses and benefit from unlimited combinations. Polyethylene tube, diameter 25mm, rigid plastic with safety plugs. Various colours.

Ref	Product description
K5029	Set of 8 poles - 60cm long
K5030	Set of 8 poles - 100cm long
K5035	Set of 8 poles - 120cm long
K5036	Set of 8 poles - 160cm long



**MULTI-FUNCTIONAL BASE**

Weighted base. Can accommodate poles, flat hoops and hula hoops.

Ref	Product description
10191	Multi-function base - sold by unit

# TRAINING / DRILLS

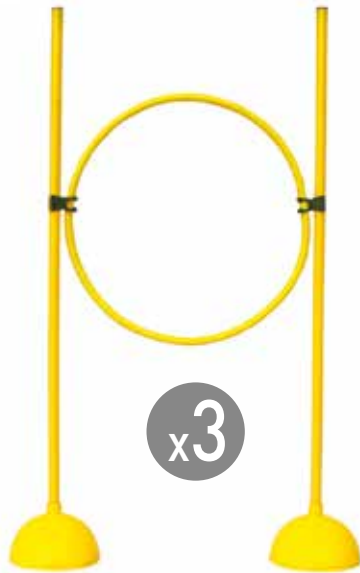

## TARGET HOOPS

Kit offering multiple combinations for developing mobility and throwing.  
Composition: 3 x 75cm diameter hoops, 6 blocks, 6 x 1.80m rods and 6 fixing clips.

Ref	Product description
10190	Set of 3 Target Hoops



## MULTI-DISCOVERY KIT

Ideal for setting up your mobility courses. Composition: 4 x 50cm. multi-game cones with 16 holes, 6 x 120cm rods, 4 assorted flat hoops (Ø 35 - 50 - 60 - 70cm), 8 multi-clips. Assorted colours

Ref	Product description
K5075	Multi-Discovery Kit



## MULTI-FUNCTION HURDLES

Each hurdle comprises of 3 poles (diameter 25mm - height 160cm), 2 rigid bases to be weighted and two pole clips.

Ref	Product description
10400	Set of 5, with storage bag



## SLALOM POLES

Can be used in training, slaloms and other ball exercises. Length: 150cm.

**Supplied with free storage bag.**

Ref	Product description
K5037	Slalom poles (Set of 12)

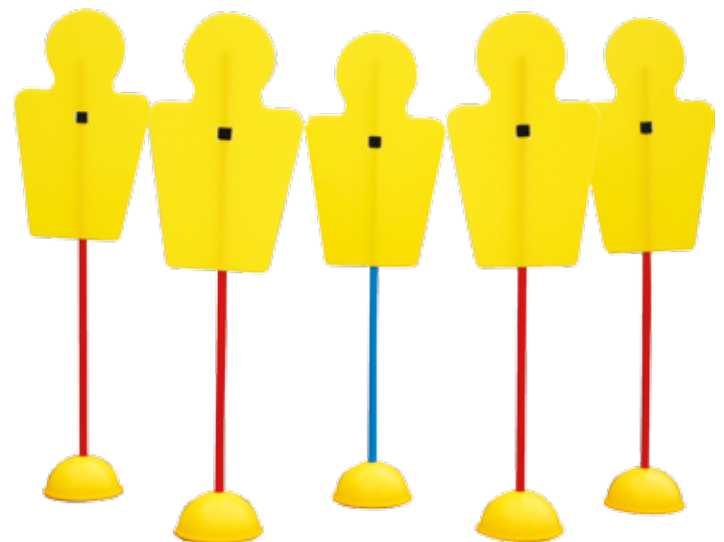

## TRAINING DUMMY SHAPES

Very useful for dribbling courses, attack and defence exercises. Made of 5 bust shapes from soft PVC, height 64cm, 5 bases and 5 rods height 150cm.

Ref	Product description
Sc120	Set of 5 training dummy shapes



**BASIC KIT**

Contents	
15cm step hurdles	Quantity 6
5cm flat cones	Quantity 12
6m foot speed ladder	Quantity 1
1 storage bag	

**PACK0001**



**FUNDAMENTALS KIT**

Contents	
15cm step hurdles	Quantity 6
5cm flat cones	Quantity 12
28cm cones	Quantity 12
6m foot speed ladder	Quantity 1
120cm speed chute	Quantity 1
1 storage bag	

**PACK0002**



**PLUS KIT**

Contents	
15cm, 28cm, 32cm step hurdles	Quantity 2 of each
28cm cones	Quantity 12
6m foot speed ladder	Quantity 1
120cm speed chute	Quantity 1
1 storage bag	

**PACK0003**



**TRAINING KIT**

Contents	
6m agility ladder	Quantity 1
Round base 28cm cones	Quantity 8
15cm step hurdles with carry strap	Quantity 10
Resistance belt	Quantity 1
1 storage bag	

**PACK0004**



**ECO KIT**

Contents	
6m agility ladder	Quantity 1
5cm flat cones	Quantity 12
6m foot speed ladder	Quantity 1
120cm speed chute	Quantity 1
1 storage bag	

**PACK0005**



**FUN KIT**

Contents	
15cm step hurdles	Quantity 6
6m agility ladder	Quantity 1
5cm flat cones	Quantity 10
22cm cones	Quantity 10

**PACK0006**

# TRAINING / DRILLS



## METAL BALL CAGE WITH WHEELS

Steel frame and welded mesh, epoxy paint, top opening for easier use (locks with padlock, supplied) – swivelling wheels, diameter 10cm.

Ref	Product description
70040	Cage dim. 55 x 60 x 94cm
70041	Cage dim. 100 x 65 x 94 cm



## STORAGE LOCKER FOR BALLS – 1 DOOR

Steel frame and welded mesh. Shelves on adjustable bars. 4 swivelling wheels. Locks with padlock, supplied.

Ref	Product description
SC109	Locker dim. 100 x 57 x 112cm
SC110	Locker dim. 80 x 57 x 157cm



## FOLDAWAY BALL BASKET

Capacity 15 balls, aluminium wheeled structure, reinforced canvas.

Ref	Product description
SC20	Foldaway basket



## METAL BALL RACK

Made from painted tubular steel, equipped with 4 swivelling wheels, capacity 24-40 balls.

Ref	Product description
SC100	Ball rack dim. 156x51x143cm



## MULTI-PURPOSE TRANSPORTATION CART

Ref	Product description
10107	Cart dim. 105x85x105cm

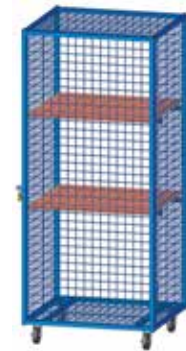

Ref SC111

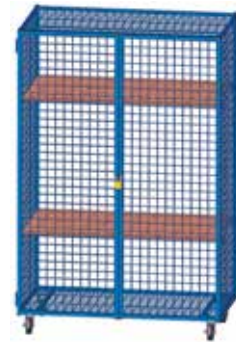

Ref SC112



## VERTICAL RACK FOR MEDICINE BALLS CAPACITY UP TO 5 MEDICINE BALLS DEPENDING ON SIZE

Painted steel tubing. Supplied unassembled.

Ref	Product description
SC101	Vertical rack for medicine balls



## TALL EQUIPMENT CUPBOARD 2 SLIDING DOORS

Ref	Product description
SC116	Tall equipment cupboard 2 sliding doors – dim : 201 x 65 x 188 cm



Ref SC113

Ref SC114

## EQUIPMENT CUPBOARDS

Steel frame and welded mesh 50 x 50mm, epoxy paint finish, 4 swivelling wheels, locks with padlock (supplied). Widths designed to go through doorways.

Ref	Product description
SC111	Tall cupboard 1 door 2 shelves dim 84 x 72 x 188 cm
SC112	Tall cupboard 2 doors 2 shelves dim 120 x 70 x 183 cm
SC115	Tall cupboard 2 doors 2 shelves dim 150 x 54 x 157 cm
SC113	Low cupboard 2 doors 2 shelves dim 150 x 54 x 97 cm
SC114	Low cupboard 4 doors 4 sections dim 150 x 54 x 103 cm





### MULTI-USE MESH STORAGE BAG

Re-discover the quality of the DIMA bag with this extremely resistant bag made from anti-spike PVC double coated (air mesh), specifically designed to hold your balls, small equipment items, etc. Fitted with two tear-proof handles, closes with Velcro.

Ref	Product description
SC60	Multi-use mesh storage bag



### MULTI-USE CANVAS STORAGE BAG

Made from 1000 denier tergal, fitted with tear-proof handles.

Ref	Product description
SC61	Multi-use canvas storage bag 90 x 35 x 35cm



### MULTI-USE LARGE VOLUME STORAGE BAG

Made from high-resistance 1000 denier Tergal. Wide opening on 3 sides fitted with a zip. Dimensions 100 x 70 x 60cm.

Ref	Product description
10830	Multi-use large volume storage bag



### SAILOR'S BAG

Holds all your small equipment items for your sports activities. Made from polyester fibre allowing fast drying of equipment. Closes with a drawstring.

Ref	Product description
SC62	Sailor's bag dim. 90 x 65cm
SC63	Sailor's bag dim. 90 x 110cm

### DIMA BAG

With a reputation for solidity and great resistance, washable and rainproof, the DIMA bag will accompany you throughout your sporting career and even afterwards...

**Dimensions :** Small bag Dima 50 x 37 x 30cm  
Large bag Dima 70 x 46 x 40cm

#### CUSTOMISED DIMA BAG

Create your logo, we will silk-screen print it. Send your design to DIMA with your order form, by fax, post, or e-mail.

Ref	Product description
10832	Large Blue Customized Bag
10833	Large Red Customized Bag
10834	Small Blue Customized Bag
10791	Small Red Customized Bag

**NOTE: MINIMUM ORDER OF 30 BAGS**

### STANDARD DIMA BAG

Specially adapted for transporting heavy equipment, this bag, made from 1,000 denier Tergal fabric, with tearproof transportation handles, will become an essential transportation tool for your training sessions.

Dimensions:  
- 50 x 37 x 30cm (Ref. 10789-10790)  
- 70 x 46 x 40cm (Ref. 10801-10802)

Ref	Product description
10801	Large Blue Bag
10802	Large Red Bag
10790	Small Blue Bag
10789	Small Red Bag



**Customise your bags with your logo on request**



# DIMASPORT

SPORTS EQUIPMENT

## MANUFACTURER

WE MANUFACTURE OUR PRODUCTS IN OUR FACTORIES NEAR PARIS.

### COVER WORKSHOP



FOR MORE THAN 50 YEARS, we have constantly improved our expertise to offer **quality products**. Seams of the best quality, double or quadruple stitched according to requirements. Special shapes, flat surfaces, any specific requests, **our team will meet all your requirements.**



### OUR RAW MATERIALS



Our foams are of the highest quality, and we know their composition.



Our canvases are inspected and certified.



We require unremittingly high standards from our suppliers, because the quality of our raw materials largely guarantees the quality of our products.

Foam is a costly but fundamental component in our products; we are constantly attentive to its quality and make no compromises.

### PRODUCT TESTING AND INSPECTION



Our products are **inspected and certified**

**DIMA IS A COMMITTED AND RESPONSIBLE FIRME**

As manufacturers, we guarantee the products that we make.

RESPONSIBLE FOR PRODUCTION  
TO FULFIL **YOUR SATISFACTION**  
**TOTAL COMMITMENT FROM DIMA**



## DIMA, INVENTOR OF SPORTS EQUIPMENT

### CREATOR

CLOSE TO GRASS-ROOTS NEEDS, WE REMAIN ATTENTIVE TO YOUR REQUIREMENTS AND REGULARLY BRING OUT NEW PRODUCTS.

As manufacturer, we make standard equipment but can also make to your measurements and fulfil your requirements. We manufacture our products in our factories near Paris.

## CONTENTS

# SPORTS HALL EQUIPMENT

### CLIMBING

Crash mattresses for climbing walls and boulders 40cm thick.....	84
DIMA climbing crash pads.....	84
Landing mats for artificial climbing structures 5cm or 10cm.....	85

### WRESTLING

Beginners wrestling mat.....	86
Reversible multi-sport surfaces.....	86
Club wrestling mat.....	86
Reversible covers – 1 circle/4 circles.....	87
School wrestling and combat mats.....	87

### JUDO

Cotton tatamis.....	87
Vinyl tatamis.....	87
Afnor tatamis.....	87
Cotton judo covers.....	87
Rice straw type judo covers.....	87

### PILLAR AND WALL PROTECTORS

Made-to-measure post protectors for outdoor use.....	88
Rugby post protectors.....	88
Wall pads for indoor and outdoor use.....	89

# SPORTS HALL EQUIPMENT

- Made from a 1000 denier tergal cover with leather grain upper and non-slip underside.
- **Certified flame-retardant (M2 French standard) and phthalate-free**
- Components can be combined using wide, self-gripping pads for perfect landing
- **Ideally suited to intensive use**



**Certified PRODUCTS**

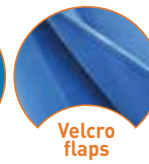
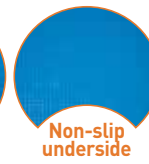

## CRASH MATTRESS FOR CLIMBING WALLS AND BOULDERS – 40CM THICK Made from polyurethane foam

Mattresses can be joined and stabilised using wide 40cm detachable self-gripping flaps on the upper side.

Ref	Product description
15931	250 x 100 x 40 cm
15936	250 x 150 x 40 cm
15933	250 x 200 x 40 cm
15941	250 x 250 x 40 cm
15942	250 x 300 x 40 cm
15935	Specific shape – sold by sqm.



### STRAPS

To hold crash pads against the wall when not in use. Width 5cm

Référence	Product description
26120	Strap – sold by linear metre

## LANDING EQUIPMENT FOR CLIMBING WALLS

This standard applies to landing equipment for climbing on artificial climbing structures such as walls and boulders where the height of the highest hold does not exceed 4.10m above the landing area.

The fall zone must correspond to the projection of the overhanging climbing wall on the ground, increased by 2.50m minimum in all possible fall directions (see drawing).

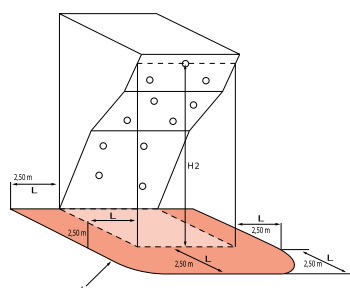

Key:  
H2: highest hold, lower than 4.10m  
A: vertical projection  
L: equal to or in excess of 2.50m



### DIMA CLIMBING CRASH PADS

This range of crash pads made from dual density foam for stable landing, has been designed specifically for safe climbing activities, guaranteeing a proper and safe landing. All our crash pads can be transported in three ways: with a shoulder strap, handles or adjustable rucksack straps.

**Composition:** 7cm of polyurethane foam (for CRASH001 MODEL) and 9cm (for CRASH002) + 3cm of firm polyethylene. Cover made from soft-touch PVC-coated canvas, both resistant and waterproof.

Ref	Product description
CRASH001	100 X 100 X 10cm dual density
CRASH002	130 X 100 X 12 dual density reversible

The CRASH002 model is reversible and can be used on the hard or soft side according to requirements, and is fitted with removable carry straps.



## MATS AND MATTRESSES FOR CLIMBING WALLS

### LANDING MATTRESSES FOR ARTIFICIAL CLIMBING STRUCTURES (Components can be combined using wide, self-gripping pads)



### MATS FOR CLIMBING WALLS

Made from dense polyurethane foam.

Mattresses can be joined and stabilised using wide 10cm detachable self-gripping flaps on the upper side.

Ref	Product description
23019	250 x 100 x 5 cm - velcro
23018	250 x 150 x 5 cm - velcro
23012	250 x 200 x 5 cm - velcro
23016	250 x 250 x 5 cm - velcro
23013	250 x 300 x 5 cm - velcro
23017	Specific shape - sold by sqm.

### MATTRESSES FOR CLIMBING WALLS

Made from dual density foam (soft polyurethane foam + a dense polyethylene layer)

Mattresses can be joined and stabilised using wide 10cm detachable self-gripping flaps on the upper side.

Ref	Product description
23021	250 x 100 x 10 cm - dual density velcro
23005	250 x 150 x 10 cm - dual density velcro
23006	250 x 200 x 10 cm - dual density velcro
23009	250 x 250 x 10 cm - dual density velcro
23007	250 x 300 x 10 cm - dual density velcro
23004	Specific shape - sold by sqm.

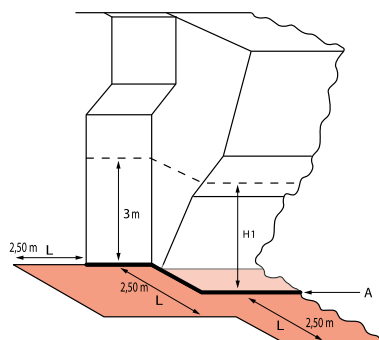

Key:  
H1: highest hold below 3.00m  
A: vertical projection  
L: equal to or in excess of 2.50m

### REMINDER OF LANDING AREA SIZE REQUIREMENTS

To map out a landing area:

- Draw a horizontal line on the structure (including its edges and sides) 3m above the ground
- Define the vertical projection from this line on the ground.

The landing area must stretch at least 2.50m beyond this line, and in all possible fall directions (see drawing) notably to prevent head contact with the ground.

The DIMASPORT team is at your disposal to help you deliver your projects to your own requirements.  
Call +33 1 64 40 05 70 or e-mail [info@dimasport.fr](mailto:info@dimasport.fr)

# SPORTS HALL EQUIPMENT



Dima lends its **expertise** in multi-purpose gymnastics mats to **combat sports**, offering you a range of surfaces for wrestling, from beginners to more intensive use, but also enabling **modularity** to allow other sports.

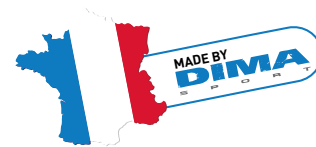

## BEGINNERS WRESTLING MAT

**Multi-purpose model for both wrestling and gymnastics**

Made up of folding tumbling tracks (see description page 18) made from dense and springy polyethylene foam. Velcro on all edges. Non-slip underside, with carrying handles. Markings heat sealed onto the tracks.

Ref	Product description
50200	600 x 600 x 4 cm (3 tracks 600 x 200 x 4 cm)
50201	600 x 600 x 6 cm (3 tracks 600 x 200 x 6 cm)
50202	800 x 800 x 4 cm (8 tracks 400 x 200 x 4 cm)
50203	800 x 800 x 6 cm (8 tracks 400 x 200 x 6 cm)



**HEAT-SEALED MARKINGS ON TRACKS**



**REVERSIBLE SYSTEM**  
1 SIDE WRESTLING + 1 SIDE JUDO

## REVERSIBLE MULTI-SPORT SURFACE

**Ideal for beginners**, this system offers a host of possibilities for wrestling and judo but also gymnastics. Made from roll-up tracks. Made from springy and lightweight polyethylene foam covered with a red carpet (35mm). Special non-slip underside. Covered with a 1000 denier Tergal covering, fire-resistance-treated to M2 (French) standard. One side with wrestling markings and the other with judo markings (heat sealed). Combined and assembled using 10cm wide Velcro. (Eyelets on request.)

### FULL AREA

Ref	Product description
50204	600 x 600 x 4 cm (3 tracks)
50209	800 x 800 x 4 cm (4 tracks)
50214	1000 x 1000 x 4 cm (5 tracks)

### COVER ONLY

Ref	Product description
50221	600 x 600 cm
50222	800 x 800 cm
50223	1000 x 1000 cm

## CLUB WRESTLING MAT

**High quality model.** Made from a set of dense and springy 4 or 6cm polyurethane panels and a traditional cover.

1000 denier PVC cover, certified fire-resistant M2, with reinforced corners. Protective flap on all edges with fixing eyelets. Velcro on request. Heat-sealed markings. Colours: blue/red (other colours on request)

### FULL MAT

Ref	Product description
50205	600 x 600 x 4 cm
50210	600 x 600 x 6 cm
50206	800 x 800 x 4 cm
50211	800 x 800 x 6 cm
50207	1000 x 1000 x 4 cm
50212	1000 x 1000 x 6 cm
50208	1200 x 1200 x 4 cm
50213	1200 x 1200 x 6 cm

### COVER ONLY

Ref	Product description
50215	600 x 600 cm
50216	800 x 800 cm
50217	1000 x 1000 cm
50218	1200 x 1200 cm



**EXCELLENT VALUE FOR MONEY**

**5** year guarantee



**REVERSIBLE COVER 1 CIRCLE / 4 CIRCLES**

**Adaptable model**

1000 denier Tergal cover with M2 flame-retardant certification, one side with 1 circle and one side with 4 circles. Cover attaches using 10cm-wide Velcro bands or rings. Colours: yellow/red [other colours on request].

Ref	Product description
50219	1000 x 1000 cm
50220	1200 x 1200 cm

**REVERSIBLE COVER  
1 CIRCLE / 4 CIRCLES**

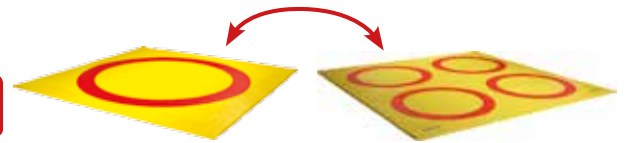

**VINYL TATAMIS**

**Compliant with European standard 12503-3. High quality tatamis.**

230kg/m3 density foam. Heat sealed corners for vinyl quality. Non-slip underside. Colour: red or green. **MINIMUM ORDER: 18 UNITS.**

Ref	Product description
50030	200 x 100 x 4 cm
50031	200 x 100 x 5 cm
50032	200 x 100 x 6 cm

**COTTON TATAMIS**

**Compliant with European standard 12503-3. High quality tatamis.**

230kg/m3 density foam. Adhesive-bonded corners for cotton covers. Non-slip underside. Colour: orange or green. **MINIMUM ORDER: 18 UNITS.**

Ref	Product description
50020	200 x 100 x 4 cm
50021	200 x 100 x 5 cm
50022	200 x 100 x 6 cm

**AFNOR TATAMIS**

**Compliant with French standards NFS52319 and NF 52307**

Tatamis presenting the best shock absorption, pressure resistance, consistency and energy return. Available in vinyl cover (red or green) or cotton cover (orange or green). **MINIMUM ORDER: 18 UNITS.**

Ref	Product description
50040	200 x 100 x 5 cm



**SCHOOL WRESTLING MAT / COMBAT AREA**

Sports area made of polyethylene foam covered with 1000 denier PVC.

**Full description and other sizes, see page 19.**

Ref	Product description
23751	400 x 400 x 4 cm
23752	500 x 500 x 4 cm



**COTTON JUDO COVER**

**SAFETY:** Heavy cotton canvas, stain-proof, colourfast and fungicide-treated. Bands are triple over-stitched.

**COMFORT:** perimeter fitted with eyelets for stretching. Protective flaps.

Ref	Product description
50100	Sold by sqm

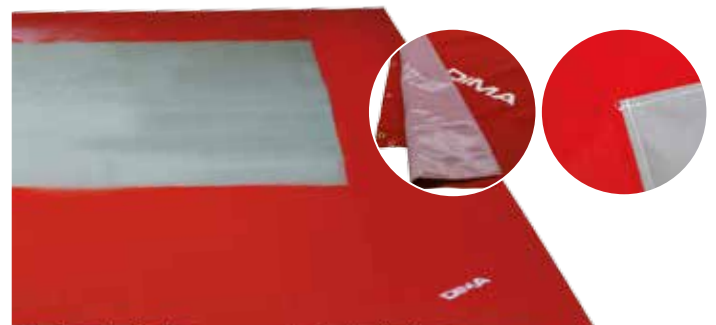

**RICE STRAW-TYPE JUDO COVER**

**SAFETY:** PVC "rice straw"-type cover. Strips triple-overstitched on flat band for total solidity and safety.

**COMFORT:** perimeter fitted with eyelets for stretching, with protective flaps. Sizes, colours and surround: please specify at time of order. Colours: red/green.

Ref	Product description
50110	Sold by sqm

# SPORTS HALL EQUIPMENT



AFTER



BEFORE



**PROTECTION OF INDOOR OR OUTDOOR PILLARS**  
**Essential for protecting and making safe all posts and pillars** in public and private spaces (kindergartens, playschools, gymnasiums, roofed playgrounds, etc.

- Made from polyurethane foam (cylindrical) or polyethylene foam (square).
- Covered with a 1000 denier canvas, fire-proof certified M2 and phthalate-free..
- Fixed wide Velcro bands for cylindrical protectors and 4 closed sides.
- Adjustable using wide Velcro bands (fixing straps on the pillar and flaps stitched onto the protector).
- Choice of colours.

## STANDARD CANVAS PILLAR PROTECTOR

Ref	Product description
40260055	Square/rectangular pillar protector plain colour thickness 4cm – sold by sqm
40260061	Cylindrical post protector made to order thickness 3cm – sold by sqm
40260060	Customised pillar protectors

## KID COVER PILLAR PROTECTORS

Ref	Product description
KB0601	Square/rectangular pillar protector thickness 4cm – sold by sqm
KB0600	Cylindrical post protector MADE TO ORDER thickness 3cm – sold by sqm



**Our sales team is here to help;  
 please feel free to contact us**

**info@dimasport.fr** **+33(0)1 64 40 05 70**

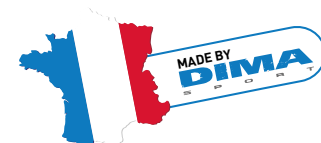

## RUGBY POST PROTECTORS

Polyurethane foam protector, covered on 6 sides with a 1000 denier PVC canvas. Fixed with Velcro fastenings from top to bottom.

## RUGBY POST PROTECTORS

Ref	Product description
40260059	Set of 4 post protectors 30x30cm - Height 2m
40260010	Set of 4 post protectors 50x50cm - Height 2m

**All other team sport protectors  
 made to measure, on request**



## CHOICE OF COVER COLOURS

We offer you a wide range of colours to help you to harmoniously incorporate your future protection pads into your premises. Colours can be chosen from the palette below.

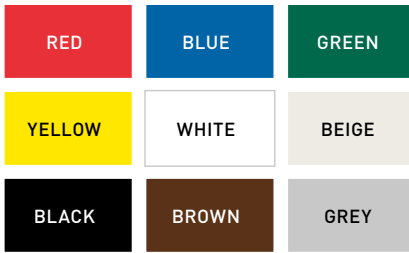

## CHOICE OF KID COVER COLOURS



### DIMA MANUFACTURER

We make your protectors to your measurements, (specific shapes, etc.). Do not hesitate to ask us.

#### PILLAR PROTECTORS

- Measurements of each side of the pillar, specifying the number of faces to be protected
- Height of the protector to be supplied
- If the pillar is round, the diameter or circumference of the pillar.

#### WALL PADS

- Width + height of protectors
- Sizes and locations of any cut-out shapes to be included, where relevant.

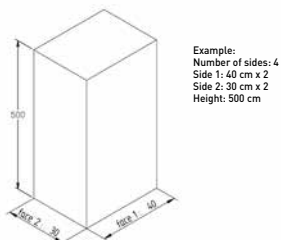
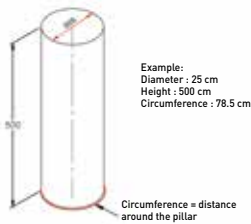

## INDOOR AND OUTDOOR WALL PADS

### WALL PADS

Essential for protecting risk areas, these protective pads contribute to a safer sports environment. Made from dense polyethylene foam, covered with a PVC M2 fireproof phthalate-free canvas. Fix to wall with Velcro. Choice of colours.

### STANDARD CANVAS WALL PADS

Ref	Product description
23800011	200 x 100 x 3cm panel
23800012	200 x 100 x 4cm panel
23800010	4cm thick pad with specific shapes – sold by sqm
23800013	3cm thick pad with specific shapes – sold by sqm



## SAFETY RULES

In a dojo, when there is less than 1m between the wall and the edge of the tatami, it is compulsory to fit the walls with protective pads.



### KID CANVAS WALL PAD

Choice of colours.

Ref	Product description
KB0606	100 x 100 x 3cm panel
KB0607	200 x 100 x 3cm panel
KB0651	3cm thick pad with specific shapes – sold by sqm



# DIMA SPORT

SPORTS EQUIPMENT

## MANUFACTURER

WE MANUFACTURE OUR PRODUCTS IN OUR FACTORIES NEAR PARIS.

### METALWORK

We cut, drill and weld the steel ourselves.  
Every production stage is rigorously controlled.



### OUR SUPPLIERS

are firms with whom we have been **working for many years** and with whom we work **in close cooperation to develop our products**.  
To guarantee your satisfaction,

**Dima remains scrupulously attentive to the quality of the products it offers.**

### OUR SERVICES

**We have very reactive delivery times** (the vast majority of our products are in stock in our factory). We can therefore deliver goods to you quickly.  
We transport our goods ourselves.

**WITH DIMA, A SINGLE POINT OF CONTACT, WHATEVER YOUR QUESTION**

RESPONSIBLE FOR PRODUCTION  
TO FULFIL **YOUR SATISFACTION**  
TOTAL COMMITMENT FROM DIMA



## DIMA: DESIGNER OF SPORTS EQUIPMENT

### CREATOR

CLOSE TO GRASS-ROOTS NEEDS, WE REMAIN ATTENTIVE TO YOUR REQUIREMENTS AND REGULARLY BRING OUT NEW PRODUCTS.

We are always on the lookout for innovative products to improve performance. In this chapter, you will find new product ranges.

## CONTENTS

# MULTISPORTS

<b>Badminton</b> .....	92
Rackets and accessories.....	92
Badminton posts.....	94
<b>Table tennis</b> .....	96
<b>Orienteering</b> .....	97
<b>Juggling and circus</b> .....	98
<b>Circus school packs</b> .....	100

# MULTISPORTS

## BADMINTON RACKETS

**Isometric rackets equalise the length of the strings for a 32% larger sweet spot compared to standard rackets.**

This technology gives you more precision when hitting, as well as additional power and control.

**DIMA+**  
**EXTRAS**

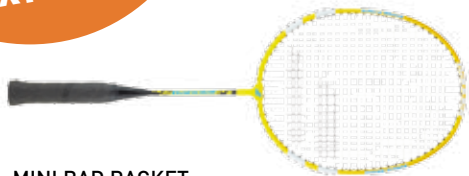

### MINI BAD RACKET

**Especially designed for beginner-level children from 4 to 7 years.**

Aluminium head - Tempered steel shaft - Weight: 89 g - Length 54 cm

Ref	Product description
BAD400	Mini bad racket



### JUNIOR 2 RACKET

**Ideal for children aged 7-9 starting to play badminton**

Aluminium head - Tempered steel shaft - Weight: 100 g - Length 62 cm

Ref	Product description
BAD410	Junior 2 racket

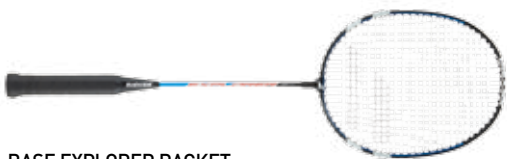

### BASE EXPLORER RACKET

**The ideal racket for secondary-school children due to its sturdiness.**

Aluminium head - Tempered steel shaft - Weight: 110 g - Length 66.2 g

Supplied with racket head cover.

Ref	Product description
BAD500	Base explorer racket



### BASE SPEEDLIGHTER RACKET

**A light and rapid racket. Offers comfort and sturdiness thanks to its integrated T-piece.**

100% aluminium racket - Weight: 100g - Length: 66.2 cm

Supplied with racket head cover.

Ref	Product description
BAD530	Base speedlighter racket



### MINI BAD KIT

This kit includes:

20 mini bad rackets

4 tubes of 6 Babolat Practice Medium shuttlecocks

1 carry bag

**KITBAD01**



### JUNIOR 2 KIT

20 Junior 2 rackets

4 tubes of 6 Babolat Practice Medium shuttlecocks

1 carry bag

**KITBAD02**



### BASE EXPLORER KIT

20 Base Explorer rackets

4 tubes of 6 Babolat Practice Medium shuttlecocks

1 carry bag

**KITBAD03**



### SPEEDLIGHTER EXPLORER KIT

20 Base Speedlighter rackets

4 tubes of 6 Babolat Practice Medium shuttlecocks

1 carry bag

**KITBAD04**



### FIRST LITE RACKET

**Powerful and light racket. The first racket in the range with graphite shaft. Enhances the game by increasing precision.** Aluminium racket head – Graphite shaft – Weight: 92 g - Length: 66.2 cm Supplied with racket head cover.

Ref	Product description
BAD550	First Lite Racket



### FIRST LITE KIT

This kit includes:  
20 First Lite rackets  
4 tubes of 6 Babolat Practice Medium shuttlecocks  
1 carry bag

<b>KITBAD05</b>	First Lite Kit
-----------------	----------------



### MEDIUM PRACTICE

**Entry price shuttlecock recommended for leisure and school use.** Plastic base, plastic skirt.

Ref	Product description
BAD620	Tube of 6 white shuttlecocks
BAD621	Tube of 6 yellow shuttlecocks



### MEDIUM TOURNAMENT

**Shuttlecock recommended for training.** Cork base, nylon skirt, white or yellow.

Ref	Product description
BAD640	Tube of 6 white shuttlecocks
BAD643	Tube of 6 yellow shuttlecocks



### MEDIUM CUP

**Competition-grade shuttlecock, UNSS approved.** Cork base, nylon skirt. Resulting from Babolat R&D, this shuttlecock offers a high-quality game thanks to its well-studied design: trajectory similar to that of a feather shuttlecock with the advantage of a very long life.

Ref	Product description
BAD660	Tube of 6 white shuttlecocks
BAD661	Tube of 6 yellow shuttlecocks



### HEIGHT MEASURE

Complies with regulations. Used in competitions. Height from 0.85 to 3.00 m

Ref	Product description
11581	Height measure



### WALL RACK

A very practical storage system which fixes to the wall with wall plugs. Can store up to 20 badminton rackets. Supplied without rackets or attachment screws.

Ref	Product description
BAD200	Wall rack



### TRANSPORTATION TROLLEY

Ideal for school PE lessons or badminton clubs. Solid and easy-to-move cart with 4 omnidirectional roller wheels. Can store up to 100 badminton rackets and 50 tubes of shuttlecocks. Dimensions: Length 66 x Width 60 x Height 96 cm - Weight: 13 kg

Ref	Product description
BAD210	Transportation trolley

# MULTISPORTS

**78KG  
BALLAST**



## COMPETITION-LEVEL POST AND NET SETS

Compliant with regulations and certified according to French Badminton Federation (FFBa) standards - Regional and national FFBa rating No. PF06-2008. Compliant with standard EN 1509. Height adjustable from 1400 mm (wheelchair) to 1550 mm (valid)

Free-standing posts with two regulation height settings (can be simply adjusted between 1.40 m and 1.55 m), composed of a square 40 x 40 x 2 mm tube and a heavy duty 78 kg baseplate, fitted with 2 non-marking wheels (50 mm diameter) for easy movement. Our competition-grade posts are fitted with a stabilisation and adjustment jack. The net is guided with a pulley, making it easy to adjust the tension. The upright is reinforced with a brace. The net is fitted with 2 cleats on the outside. Stabilisation jack. Epoxy coating. Set of 2 posts and net - Total weight 166 kg

Ref	Product description
BAD131	Posts with net

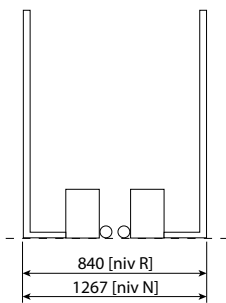

Easy net assembly



Adjustment and stabilisation jack.



Net adjustment and tensioning.



Two non-marking Ø 50 mm wheels for easy movement.

### FFBa approved

Rating No. PF06-2008  
National, Regional and  
Handibad

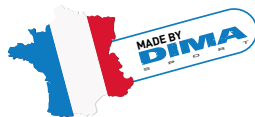

## MINI BADMINTON SET

Portable set of posts and net. Metallic tubes pre-assembled with internal cable for fast and practical assembly and removal. The net (3 metres long) is designed to be directly mounted on the structure simply by locking in. Height adjustable net from 1.37 to 1.57 m. Supplied with carry bag. Dimensions when folded: 100 x 20 x 20 cm - Dimensions when unfolded: Length 3.05 m - Height from 1.37 to 1.57 m. Wheelbase on floor: 90 cm.

Ref	Product description
BAD190	Mini badminton set



## IBF YONEX COMPETITION NET

Designed for competition use.

IBF approved (International Badminton Federation)

Standard net size 6.10 x 0.76 m. Regulation mesh of 19 mm. White PVC-coated fabric headband. Upper and lower tension adjustable with cord. Official net of the French badminton championships and the French Open.

Ref	Product description
BAD170	6.10 x 0.76 m

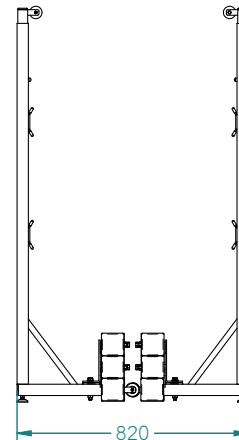

## FOAM PROTECTION

To protect post ballasts to ensure safe play.

Fits BAD131 competition posts.

In dense Neopolen foam covered in 1000 denier Tergal fabric with M2 fire rating. Colour: blue

Ref	Product description
BAD600	Pair of protectors

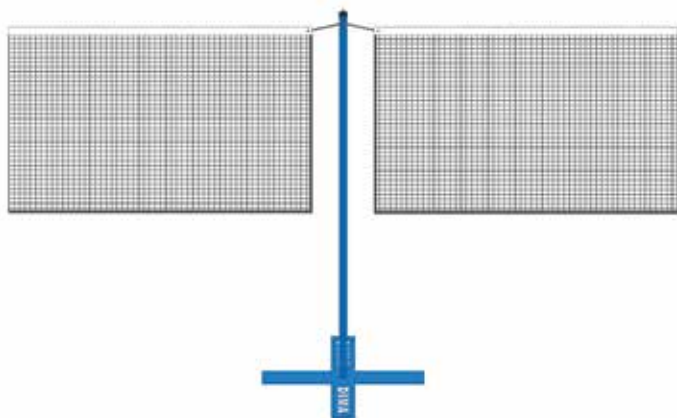

## INTERMEDIATE BADMINTON POST

Intermediate post on which to put two nets.

Regulation height: 1.55 m. Per post - Supplied without net.

Ref	Product description
BAD117	Intermediate post

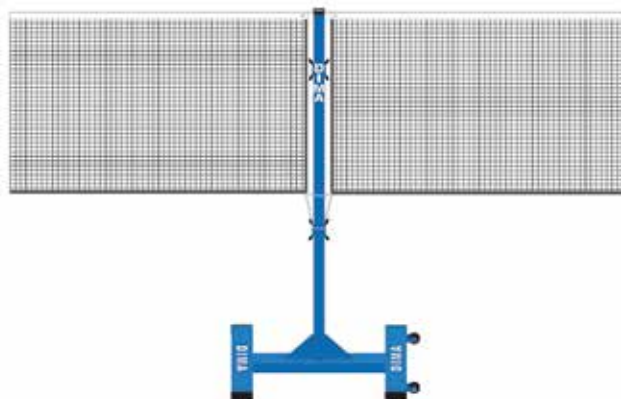

## DUAL TRAINING BADMINTON POST

Self-standing post with regulatory height to double the playing area.

Compliant with standard EN 1509

Fitted with 2 polypropylene wheels for easy movement. The 2 nets are fitted with 2 cleats on the outside.

Supplied without a net. Footprint: 71 cm (minimum space between 2 courts) x 51 cm

Central post - Total weight 24.2 kg

Ref	Product description
BAD115	Dual training badminton post

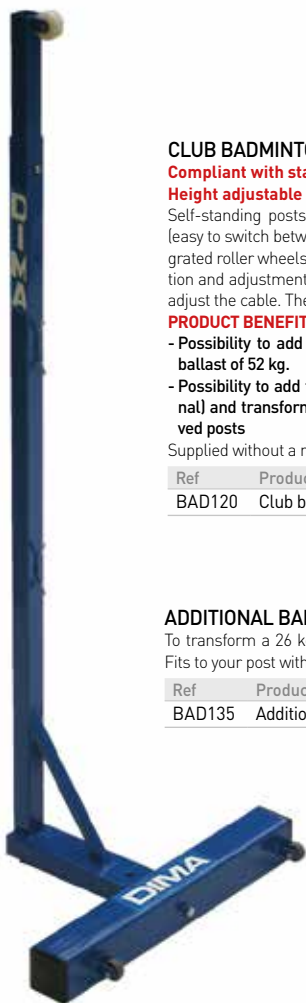

## CLUB BADMINTON POSTS 26 KG

Compliant with standard EN 1509.

Height adjustable from 1400 mm (wheelchair) to 1550 mm (valid).

Self-standing posts (heavy duty 26 kg baseplate), regulation dual height (easy to switch between 1.40 m and 1.55 m), fitted with 2 non-marking integrated roller wheels (diameter 50 mm). Our posts are fitted with a stabilisation and adjustment jack. The net is guided with a pulley, making it easy to adjust the cable. The net is fitted with 2 cleats on the outside.

### PRODUCT BENEFITS:

- Possibility to add a 26 kg ballast (ref. BAD135 optional) to reach total ballast of 52 kg.

- Possibility to add two additional ballasts (Ref. BAD135 + BAD136 optional) and transform your posts into FFBA Regional and National-approved posts

Supplied without a net. - Set of 2 posts - Total weight 62 kg

Ref	Product description
BAD120	Club badminton posts

## ADDITIONAL BALLAST NO. 1

To transform a 26 kg club post (BAD120) into a 52 kg club post (BAD130).

Fits to your post with a screw. Set of 2 x 26 kg ballasts - Total weight 52 kg

Ref	Product description
BAD135	Additional ballast No. 1

## CLUB BADMINTON POSTS 52 KG

Compliant with standard EN 1509.

Height adjustable from 1400 mm (wheelchair) to 1550 mm (valid).

Free-standing posts with two regulation height settings (can be simply adjusted between 1.40 m and 1.55 m), composed of a square 40 x 40 x 2 mm tube and a heavy duty 52 kg baseplate, fitted with 2 non-marking integrated roller wheels (diameter 50 mm). Our posts are fitted with a stabilisation and adjustment jack. The net is guided with a pulley, making it easy to adjust the cable. The upright is strengthened with a brace. The net is fitted with 2 cleats on the outside.

**PRODUCT BENEFITS:** Possibility to add an additional ballast (Ref. BAD136 optional) and transform your posts into FFBA Regional and National-approved posts.

Supplied without a net. - Set of 2 posts - Total weight 114 kg

Ref	Product description
BAD130	52 kg Club badminton posts

## ADDITIONAL BALLAST NO. 2

To transform a 52 kg post (BAD130) into a 78 kg post (BAD131). Fits to your post with a screw.

Ref	Product description
BAD136	Additional ballast No. 2

Badminton posts	Bad 130 (52 kg)	Bad 131 (78 kg)
Bad120	+ 26 kg ballast (BAD135)	+ 26 kg ballast (BAD136)
Bad 130		+ 26 kg ballast (Bad 136)

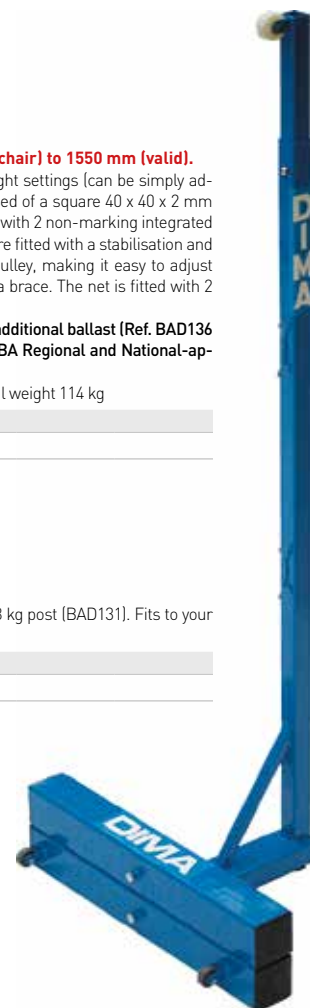

## BEGINNER NET

Flexible, knotted nylon, 25mm mesh

Ref	Product description
BAD150	Beginner net 6.10 x 0.76 m - sold individually

## TRAINING NET

Flexible nylon, regulation 19 mm knotted mesh with PVC-coated headband

Ref	Product description
BAD160	Training net 6.10 x 0.76 m - sold individually

# MULTISPORTS



## SPORT ONE CORNILLEAU TABLE

**FFTT approved for leisure**

Wooden table top (30 mm chipboard for the indoor model and 40 mm laminated for the outdoor), with corrosion-resistant steel frame. Height 30 mm. Fitted with 150-mm diameter wheels. Adjustable net tension. Adjustable feet.

Compact size: 1.55 x 0.75 m.

Side storage for bats.

New push & lock system: the table is locked and unlocked with buttons located at the bottom and top of the side of the table.

8 locking points, Compliant with safety standard EN14468-1.

Indoor table - Weight: 68 kg - Warranty: 3 years.

Outdoor table - Weight: 45 kg - Warranty: 10 years for outdoor tables.

Ref	Product description
TT410	Sport one indoor table
TT411	Sport one outdoor table



## PRO 540 OUTDOOR TABLE

**Table for outdoor use and educational use**

**FFTT approved for leisure**

7 mm MAT TOP resin table (10 times less reflection) with corrosion-resistant steel frame. Height 60 mm. 90 x 25 mm integral leg assembly.

DSI system: automatic table locking (4 safety bolts and 8 locking points in the play position and storage position).

Ergonomic unlocking handle.

Sturdy steel sides, steel net, all-surface wheels with brakes and notched tyres, protective corners.

Weight: 84 kg - Warranty: 3 years (10 years for the table top)

Ref	Product description
TT540	Table pro 540 outdoor



## PRO 510 OUTDOOR TABLE

**For camp sites, public gardens, holiday centres and hotels**

Range designed to resist shocks, impact from bats and weather conditions. Excellent bounce: 7 mm panel. MAT-TOP anti-glare coating. Permanent, non-removable steel net. Curved steel frame with system to fix it to the floor. 4 protective corners.

Outdoor table-top warranty: 10 years

Ref	Product description
TT510	Pro 510 Outdoor table



## CORNILLEAU TACTEO 50 BATS

The perfect combination of technological innovation and design.

Ref	Product description
TT050	Turquoise Tacteo 50 bat



## CORNILLEAU SPORT BAT

Ref	Product description
TT200	Cornilleau Sport 200 Bat
TT300	Cornilleau Sport 300 Bat



## CORNILLEAU PRO TABLE TENNIS BALLS

Ref	Product description
TT010	Pack of 72 Pro white balls
TT011	Pack of 72 Pro orange balls



You just need an orienteering map, a compass and you're ready to take up this outdoor mental challenge!  
 Orienteering is for **everyone and offers fun**, a bit of brain work and competition for the more athletic among us. It's great alone or as a family, from children to seniors, in the great outdoors or in the urban environment.



Orienteering is the perfect way to discover somewhere new by looking for markers or running as fast as you can over an organised course.



**EDUCATIONAL ORIENTEERING CASE**

**Orienteering kit designed for schools comprising:**

1 case, 10 compasses, 10 control punches, 10 markers, 10 check cards, 10 instruction booklets, 1 whistle

Ref	Product description
ORIENT01	Educational orienteering case



**TEACHER / STUDENT ORIENTEERING CASE**

**Orienteering kit designed for schools comprising:** 1 case, 10 compasses, 10 check cards, 10 instruction booklets, 1 whistle, 1 stopwatch

Ref	Product description
ORIENT11	Teacher / Student orienteering case



**ORIENTEERING MARKER**

Triangular marker 15 x 15 x 15 cm or 30 x 30 x 30 cm in nylon.  
 Exclusive model with three cords on the top and one cord on the bottom to hold the marker in place in all weather.  
 Hole protectors to avoid tearing.

Ref	Product description
ORIENT03	Dimensions: 15 x 15 cm Set of 5
ORIENT04	Dimensions: 30 x 30 cm Set of 5



**SET OF 10 SPECIAL CODED MARKERS  
 SECONDARY SCHOOL / COLLEGE**

Coded orienteering markers developed for PE teachers in secondary schools / colleges. Set of 10 markers numbered on both sides with 30 unique codes to allow for an unlimited number of competitors.

Ref	Product description
ORIENT02	Coded markers - set of 10



**CONTROL PUNCHES FOR ORIENTEERING**

Set of 10 control punches with different shapes, for stamping orienteering stamp cards. Set of A, B or C.

Ref	Product description
ORIENT05	Set of 10 control punches - Series A
ORIENT06	Set of 10 control punches - Series B
ORIENT07	Set of 10 control punches - Series C

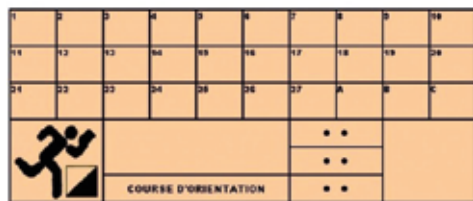

**CHECK CARDS**

Pre-printed check cards

Ref	Product description
ORIENT08	Set of 50 cards



**BEGINNER'S COMPASS**

Ideal for beginners and schools. Pendant compass with transparent liquid. Parallel direction markers and cardinal point indicators. Transparent background for back projection.

Ref	Product description
ORIENT09	Beginner's compass



**CASE OF 20 BEGINNER COMPASSES**

**Set consists of:**

1 nylon case with protective reinforcement and strap on 2 rotating hooks. Two inside pockets and zip fastening.  
 20 compasses ref. ORIENT09  
 1 booklet

Ref	Product description
ORIENT10	Case of 20 beginner compassesmm

# MULTISPORTS

Circus activities give children the opportunity to **widen** their experiences and to understand and develop their physical skills: **balance, coordination, agility, etc.** Children learn to **adjust and expand their actions thanks to a range of different sensations and emotions**, which encourage them to play within a group.



## ADJUSTABLE STILTS

Aluminium telescopic adjustable stilts.  
Aluminium footrests adjustable in 3 positions: 16, 22 and 28 cm.  
Height adjustable from 92 to 145 cm.  
Maximum supported weight: up to 50 kg.

Ref	Product description
JONGL100	Junior stilts (child-teenager)

## BALANCE BALLS

**Essential for developing good balance.**

This polyethylene ball is shock-resistant and can be used indoors.

Ref	Product description
JONGL140	Balance ball - Weight: 10 kg - ø 70 cm
JONGL150	Balance ball - Weight: 16 kg - ø 70 cm



## GO GO PEDAL RACER

Ideal for improving balance and co-ordination.  
Plastic wheels and pedals, steel axes (diameter 14 mm) and rubber tyre tread.  
Dimensions: 48 x 36 x 16 cm - Maximum weight supported: 50 kg

Ref	Product description
KBG2138	Go go pedal racer

## UNICYCLE

Ideal for improving balance and co-ordination.  
Reinforced and comfortable saddle with bumper.  
Quick tightening. Thermo-coated tubular steel frame.

Ref	Product description
JONGL120	Unicycle (6-10 years) ø 45cm
JONGL130	Unicycle (from 10 years upwards) - ø 49 cm



## GO GO BUS WITH HANDLES

Ideal for improving balance and co-ordination.  
Plastic wheels, rubber tyres, steel-reinforced pedals, steel shaft (diameter 14 mm). Steel handles (diameter 12 mm), covered in foam diameter 30 mm).  
Dimensions: 53 x 48 x 45 cm - Maximum weight supported: 90 kg

Ref	Product description
KBG213X	Go go bus with handles



## SMALL WOBBLE BOARD

Perfect for balancing skills.  
Materials: wood - the top is covered in rubber.

Ref	Product description
KBG2111	Green wobble board - ø 35 x 4.2 cm
KBG2110	Black wobble board - ø 35 x 8 cm



## ROLLA BOLLA

For developing balance. Made of a 13 cm-diameter polyethylene cylinder and a 75 cm x 25 cm wooden board with two strips of rubber (for good grip on the cylinder) and two stops. The grooves on the board avoid slipping. Weight: 3.30 kg

Ref	Product description
JONGL110	Rolla bolla



## DIABOLO

Game to develop skilfulness (Supplied with sticks).  
Free juggling book.

Ref	Product description
JONGL160	Junior Diabolo, height: 9.5 cm - ø 8 cm - Weight: 150 g - sold individually
KBGPE771	Senior Diabolo height: 11cm - ø 10 cm - Weight: 170 g - sold individually



**BEAN BAG JUGGLING BALLS**

Soft balls made of coated fabric. Ideal for school use. Set of 3.

Ref	Product description
JONGL170	Junior - ø 62 mm - Weight: 80 g - sold individually
JONGL180	Senior - ø 80 mm - Weight: 80 g - sold individually

**JUGGLING BALLS / STAGE BALLS**

PVC stage balls. Stiffer than the bean bag ball. This ball does not crush when caught and makes a number of tricks (without bouncing) possible. Their bright colours make them excellent for performances.

Ref	Product description
KBG15461	Juggling balls ø 70 mm - Weight 100 g - Set of 7



**JUGGLING RINGS**

Polypropylene rings with rounded edges to juggle safely.

Ref	Product description
KBG15460	Junior rings - ø 24 cm - sold individually
JONGL200	Senior rings - ø 32 cm - sold individually

**SPINNING PLATES**

Plastic (polypropylene) plate to spin on the end of a stick. This exercise requires agility and concentration. It fascinates and amazes children. Ideal for school performances. Diameter 25 cm. Weight: 104 g. Supplied with plastic sticks. Free juggling book.

Ref	Product description
KBG15424	Spinning plates - set of 4

**JUGGLING SCARVES**

Ideal for learning juggling tricks. In light nylon, they float up and come down again very slowly. Assorted colours

Ref	Product description
JONGL190	Junior scarves 40 x 40 cm - set of 4
KBG15382	Senior scarves 68 x 68 cm - set of 6



**DEVIL STICKS**

Supplied with two sticks. Free juggling book.

Ref	Product description
JONGL230	Junior - Length 76 cm - Weight: 490 g per unit
JONGL240	Senior - Length 67cm - Weight: 410 g per unit

**JUGGLING CLUB**

Free juggling book.

Ref	Product description
JONGL210	Junior - Length 44.5cm - Weight: 175 g - set of 3
JONGL220	Senior club - Length 48cm - Weight: 185 g - set of 3.

# MULTISPORTS



## JUGGLING DISCOVERY PACK

Ideal for learning to be a juggling expert. This pack contains:

- 3 junior clubs
- 3 bean bag juggling balls
- 1 Diabolo with sticks and string
- 1 spinning plate, including stick
- Free juggling book and carry bag

Ref	Product description
JONGL300	Set



## JUGGLING DISCOVERY PACK - 10 CHILDREN

For a group of 10 children. This pack contains:

- 9 bean bag juggling balls
- 3 Diabolos with sticks and string
- 2 spinning plates, including sticks
- 6 rings, diameter 24 cm
- 1 free juggling book.

Ref	Product description
JONGL310	Set



## JUGGLING DISCOVERY PACK - 20 CHILDREN

For a group of 20 children. This pack contains:

- 9 bean bag juggling balls
- 4 Diabolos with sticks and string
- 4 spinning plates, including sticks
- 9 rings, diameter 24 cm
- 6 junior clubs
- 6 juggling scarves
- 2 devil sticks including hand sticks
- 1 free juggling book.

Ref	Product description
JONGL330	Set



## JUGGLING DISCOVERY PACK - 15 CHILDREN

For a group of 15 children. This pack contains:

- 12 bean bag juggling balls
- 6 Diabolos with sticks and string
- 3 spinning plates, including sticks
- 6 rings, diameter 24 cm
- 1 free juggling book.

Ref	Product description
JONGL320	Set



**JUNIOR JUGGLING PACK - 10 CHILDREN**

For a group of 10 children. This pack contains:

- 6 bean bag juggling balls
- 2 Diabolos with sticks and string
- 2 spinning plates, including sticks
- 6 rings, diameter 24 cm
- 6 juggling scarves
- 1 free juggling book.

Ref	Product description
JONGL340	Set



**JUNIOR JUGGLING PACK - 15 CHILDREN**

For a group of 15 children. This pack contains:

- 9 bean bag juggling balls
- 3 Diabolos with sticks and string
- 3 spinning plates, including sticks
- 6 rings, diameter 24 cm
- 6 junior clubs
- 2 flower sticks including hand sticks
- 1 free juggling book.

Ref	Product description
JONGL350	Set



**JUNIOR JUGGLING PACK - 20 CHILDREN**

For a group of 20 children. This pack contains:

- 12 bean bag juggling balls
- 4 Diabolos with sticks and string
- 4 spinning plates, including sticks
- 12 rings, diameter 24 cm
- 6 junior clubs
- 2 flower sticks including hand sticks
- 1 free juggling book.

Ref	Product description
JONGL360	Set



**SENIOR JUGGLING PACK - 20 TEENAGERS / ADULTS**

For a group of 20 teenagers / adults. This pack contains:

- 12 bean bag juggling balls
- 4 Diabolos with sticks and string
- 4 spinning plates, including sticks
- 12 rings, diameter 32 cm
- 6 senior clubs
- 2 devil sticks including hand sticks
- 1 free juggling book.





Ref	Product description
JONGL370	Set

# PRODUCT INDEX

## GYMNASICS

<b>PEDAGO</b>  P12 - 15	<b>MATS</b>  P 16	<b>TRACKS-FLOORS</b>  P18 - 19	<b>MATTRESSES</b>  P20 - 23
<b>TRAMPETTES</b>  P23	<b>GYM APPARATUS</b>  P24 - 28		<b>KID PRODUCTS</b>  P29 - 30

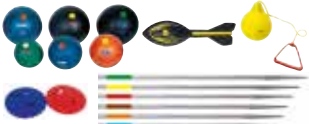
## ATHLETICS

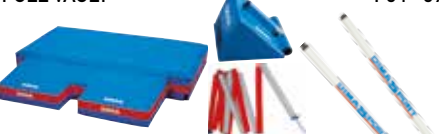
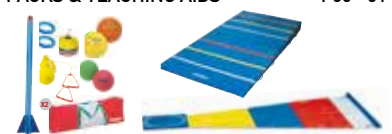
<b>TIMING - MEASURING</b>  P34 - 35	<b>SMALL EQUIP. / START</b>  P36 - 38	<b>HURDLES</b>  P39 - 43	
<b>THROWING</b>  P44 - 49	<b>HIGH JUMP</b>  P50 - 53	<b>POLE VAULT</b>  P54 - 59	<b>PACKS &amp; TEACHING AIDS</b>  P60 - 61

## TRAINING

<b>JUMPING</b>  P64 - 65	<b>STRENGTHENING</b>  P66 - 67	<b>HURDLES</b>  P68 - 70
<b>DRILL MARKINGS</b>  P72 - 78	<b>STORAGE</b>  P80 - 81	

## SPORTS HALL EQUIPMENT

<b>CLIMBING</b>  P84 - 85	<b>WRESTLING / JUDO</b>  P86 - 87	<b>PROTECTORS</b>  P88
---	--	--

## MULTISPORTS

<b>BADMINTON</b>  P92 - 95	<b>TABLE TENNIS</b>  P96	<b>ORIENTEERING</b>  P97	<b>CIRCUS &amp; JUGGLING</b>  P98 - 101
--	---	--	--

## A

Apparatus	24, 25, 26, 27
Athletics pack	58, 60
Athletics	33-61

## B

Babygym	28-31
Badminton kit	92-93
Badminton	91-95
Bags, Dima	58, 81
Balance ball	98
Ballast, badminton	95
Balls, juggling	99-101
Balls, table tennis	96
Balls, throwing	44, 49
Banners, section	35
Bars, high	26, 28
Bars, mixed	24, 25
Bars, parallel	24, 25, 28
Bars, traction	65
Bars, uneven	24, 25, 28
Base (drill markings)	77
Basket (storage)	80
Bats, table tennis	96
Beam	15, 26, 27
Belt	66, 67
Bench	64 - 65
Bricks	74

## C

Circus	98-101
Clapper	36
Climbing	83, 84, 85
Clip, rotating	77
Clubs, juggling	99
Compass	97
Cones	72, 78
Cones, flat	72
Covers, Dimagym	20-21
Cover, high jump landing system	51-52
Covers, judo/wrestling mats	86, 87
Covers, weather	51, 53, 54
Crash pads	84
Crossbars	50, 55
Cupboard	80

## D

Diabolo	98, 100, 101
Discus	46, 47
Drill markers	74, 75

## E

Elastiband	67
Elastic cord	67

## F

Floors, exercise	19
Floors, gym	18, 19

## G

Go go	98
Gymnastics	11-31

## H

Hammer	45
Height gauge	50, 55

High jump	50-54
Hoops	37, 48, 61, 74, 76, 77, 78
Hurdle	39-43, 68-70, 72, 73, 77, 78
Hurdle, foam	41, 42

## I

Incline	13
Infant agility	28-31

## J

Javelin	49
Judo	86-87
Juggling	98-101
Juggling pack	100, 101

## K

Kid courses	29, 30, 31
-------------	------------

## L

Ladder, agility 37, 75, 76	37, 75
Ladder, foot speed	37, 75
Ladder, hoop	76
Landing system	51-55
Landing system, folding	51

## M

Markers	73, 74, 77, 97
Markings, drill	72-78
Mats, climbing	84, 85
Mats, gym	16-19
Mats, jumping	61
Mats, wrestling	86, 87
Matting, judo, wrestling	86, 87
Matting, multisports	86
Mattress, 1-piece	23, 51, 52
Mattress, folding	22, 25, 26
Mattress, gym	20-25
Mattress, pole vault	54
Measurement	35
Medicine ball	45, 66
Megaphone	35
Mobility courses	74
Monocycle	98
Motor skills	38-31
Multisports	92-101

## N

Net, badminton	94, 95
----------------	--------

## O

Official's Clipboard, Dima	36
Orienteering	97
Orienteering card	97

## P

Pads, wall	89
Pedagogym	13, 71
Platform (gymnastics)	15, 27
Platform (landing system)	51, 53
Plyometric foam blocks	64
Podium	36
Podometer	35
Pole vault	54-58
Posts, badminton	94, 95
Power sled	38, 67
Prima gym	28

Protectors, pillar	88
Protectors, shed	59
Push-up bars	65

## R

Rack, storage	66, 80
Rackets, badminton	92, 93
Relay batons	36
Resistance belts	67
Rings, juggling	99, 100, 101
Rings, throwing	47
Rolla bolla	98
Rugby	88

## S

Sheds	53-59
Shot	44
Sports hall equipment	83-89
Springboard	14, 27
Staircase, foam	61
Starting blocks	38
Stilts	98
Stopwatch	34-35
Storage	81-81
Straps	84
Stride indicators	37, 75
Synthetic roll	38, 70

## T

Take-off mat	61
Tape, metric	37, 46, 72
Tape, Velcro	72
Tape, vinyl	34, 46, 74
Target	48
Tatamis	87
Throwing areas	44, 61
Throwing factsheet	46
Throwing implements	44-49
Tip, pole vault	57
Track, gymnastics	18, 19, 64
Training	63-81
Training dummies	78
Training kit	79
Trampoline	23
Trampoline	28
Transportation cart	17, 23, 39, 44-46, 49, 76, 80, 93
Turbojav	49

## U

Uprights, high jump	50
---------------------	----

## V

Vault box	55, 61
Vest, weighted	66
Vortex	49

## W

Wall bars	65
Wheel, measuring	35, 46
Whistles	36
Wrestling	86, 87

# DIMASPORT

SPORTS EQUIPMENT

1 bis, rue Louis Armand  
B.P 91 - 77834 OZOIR-LA-FERRIÈRE CEDEX  
FRANCE  
Tél. : +33(1) 64 40 05 70 - Fax : +33(1) 64 40 00 37  
www.dimasport.fr - info@dimasport.fr



DimaSport plays its part in protecting the planet. Printed on certified PEFC paper made from sustainable managed forest wood.



agencecebra.com

**GYMNASTICS**

**ATHLETICS**

**TRAINING / DRILLS**

**SPORTS HALL EQUIPMENT**

**MULTISPORTS**

